

MAJESTIC VERMONT *Castings*



**Direct Vent
Top Vent
Model**

BHDT36

Installation Instructions & Homeowner's Manual

WARNING! IF THE INFORMATION IN THIS MANUAL IS NOT FOLLOWED EXACTLY, A FIRE OR EXPLOSION MAY RESULT CAUSING PROPERTY DAMAGE, PERSONAL INJURY OR LOSS OF LIFE.

FOR YOUR SAFETY

WHAT TO DO IF YOU SMELL GAS:

- Do not try to light any appliance.
- Do not touch any electric switch
- Do not use any phone in your building.
- Immediately call your gas supplier from your neighbours phone. Follow the gas suppliers instructions.
- If you cannot reach your gas supplier call the fire department.

FOR YOUR SAFETY

**DO NOT STORE
OR USE GASOLINE OR OTHER
FLAMMABLE VAPOURS AND LIQUIDS
IN THE VICINITY OF THIS OR ANY
OTHER APPLIANCE.**

- Installation and service must be performed by a qualified installer, service agency or your gas supplier.



**The Vermont Castings
Majestic Products Company**

410 Admiral Blvd., Mississauga
Ontario, Canada L5T 2N1

www.majesticproducts.com / www.vermontcastings.com



INSTALLER: DO NOT DISCARD THIS MANUAL - LEAVE FOR HOMEOWNER

10001827
11/01 Rev.1

TABLE OF CONTENTS

PLEASE READ THE INSTALLATION & OPERATING INSTRUCTIONS BEFORE USING APPLIANCE.

Thank you and congratulations on your purchase.

IMPORTANT: Read all instructions and warnings carefully before starting installation. Failure to follow these instructions may result in a possible fire hazard and will void the warranty.

Installation Instructions	3
General Information	3
Locating your Fireplace	4
Fireplace Dimensions	5
Mantels	5
Mantel Chart	5
Clearance to Combustibles	5
Framing & Finishing	5
Final Finishing	6
Hearth	6
Gas Specifications	6
Gas Line Installation	7
Remote Switch Installation	7
General Venting Information	8
Termination Clearances	9
Assembling Vent Pipes With Crimped Ends	10
Vertical Sidewall Applications	10
How To Use the Vertical Sidewall Venting Graph	11
Vertical Sidewall Installation	12
Below Grade Installations	14
Vertical Through the Roof Applications	14
Vertical Through the Roof Installation	15
Crimped End Venting Components	16
Assembling Twist Lock Vent Pipes	17
Vertical Sidewall Applications	17
How To Use the Vertical Sidewall Venting Graph	19
Vertical Sidewall Installation	19
Below Grade Installations	21
Vertical Through the Roof Applications	22
Vertical Through the Roof Installation	23
Twist Lock Venting Components	24
Operating Instructions	25
General Glass Information	25
Louvre Removal	25
Glass Cleaning	25
Glass Frame Removal	25
Installation of Logs	26
Lava Rock	26
Flame Adjustment	26
Flame Characteristics	27
Inspecting the Venting System	27
Maintenance	27
Cleaning the Standing Pilot	27
Lighting and Operating Instructions	28
Troubleshooting Gas Control (Honeywell Millivolt Gas Valve)	29
Troubleshooting Gas Control (SIT 820 Millivolt Gas Valve)	30
Replacement Parts List	31
Replacement Parts Pictorial	32
Options	33
Fan Kit - FK24	33
Bay Window Installation	33
Screen Kit	34
Ceramic Refractory Installation	34
Remote Control	34

INSTALLATION AND OPERATING INSTRUCTIONS

This gas appliance should be installed by a qualified installer in accordance with local building codes and with current CAN / CGA-B149 (.1 or .2) Installation codes for Gas Burning Appliances and Equipment. or for U.S.A Installations follow local codes and/ or the current National Fuel Gas Code. ANSI Z223.1.

FOR SAFE INSTALLATION AND OPERATION OF YOUR DIRECT VENT FIREPLACE PLEASE NOTE THE FOLLOWING:

1. This fireplace gives off high temperatures and should be located out of high traffic areas and away from furniture and draperies.
2. Children and adults should be alerted to the hazards of the high surface temperatures of this fireplace and should stay away to avoid burns or ignition of clothing.
3. **CAUTION: Due to high glass surface temperature children should be carefully supervised when they are in same room as your fireplace.**
4. Under no circumstances should this fireplace be modified. Parts having to be removed for servicing should be replaced prior to operating this fireplace again.
5. Installation and any repairs to this fireplace should be carried out by a qualified service person. A professional service person should be contacted to inspect this fireplace annually. **Make it a practice to have all of your gas fireplaces checked annually. More frequent cleaning may be required due to excess lint and dust from carpeting, bedding material, etc.**
6. Control compartments, burners and air passages in this fireplace should be kept clean and free of dust and lint. Make sure that the gas valve and pilot light are turned off before you attempt to clean this fireplace.
7. The venting system (chimney) of this fireplace should be checked at least once a year and if needed your venting system should be cleaned.
8. Keep the area around your fireplace clear of combustible materials, gasoline and other flammable vapour and liquids. This fireplace should not be used as a drying rack for clothing, nor should Christmas stockings or decorations be hung in the area of it.
9. Under no circumstances should any solid fuels (wood, coal, paper or cardboard etc.) be used in this fireplace.
10. The flow of combustion and ventilation air must not be obstructed in any way.
11. Whether the fireplace is installed directly on carpeting, vinyl tile or any combustible material other than wood, this fireplace must be installed on a metal or wood panel extending the full width and depth of the fireplace.
12. This fireplace requires adequate ventilation and combustion air to operate properly.

IMPORTANT:
PLEASE REVIEW THE FOLLOWING CAREFULLY

Remove any plastic from trim parts before turning the fireplace ON.

It is normal for fireplaces fabricated of steel to give off some expansion and/or contraction noises during the start up or cool down cycle. Similar noises are found with your furnace heat exchanger or car engine.

It is not unusual for your gas fireplace to give off some odour the first time it is burned. This is due to the curing of the paint and any undetected oil from the manufacturing process.

Please ensure that your room is well ventilated - open all windows.

It is recommended that you burn your fireplace for a least six (6) hours the first time you use it. If optional fan kit has been installed, place fan in the "OFF" position during this time.

LOCATING YOUR GAS FIREPLACE

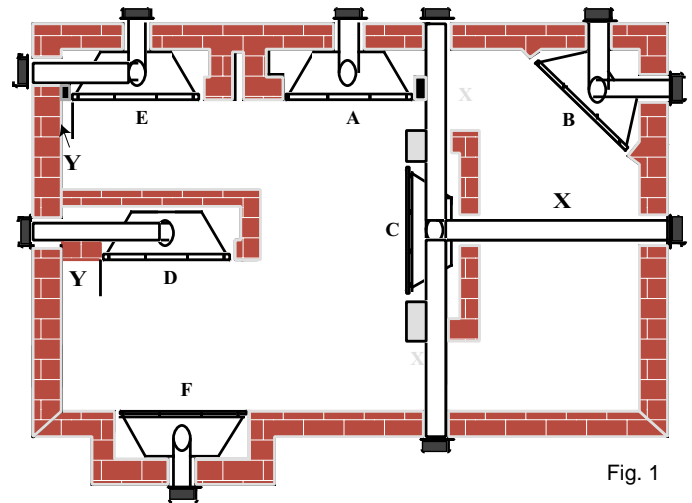

Fig. 1

- | | |
|-------------------------|-----------------------|
| A) Flat on wall | B) Cross corner |
| C) **Island | D) *Room divider |
| E) *Flat on wall corner | F) Chase installation |
| | Y) 6" minimum |

Note (Fig. 1):

** Island (C) and Room Divider (D) installation is possible as long as the horizontal portion of the vent system (X) does not exceed 20 feet (610cm). See details in Venting Section.

* When you install your fireplace in (D) Room divider or (E) Flat on wall corner positions (Y), a minimum of 6 inches (153mm) clearance must be maintained from the perpendicular wall and the front of the fireplace.

FIREPLACE DIMENSIONS

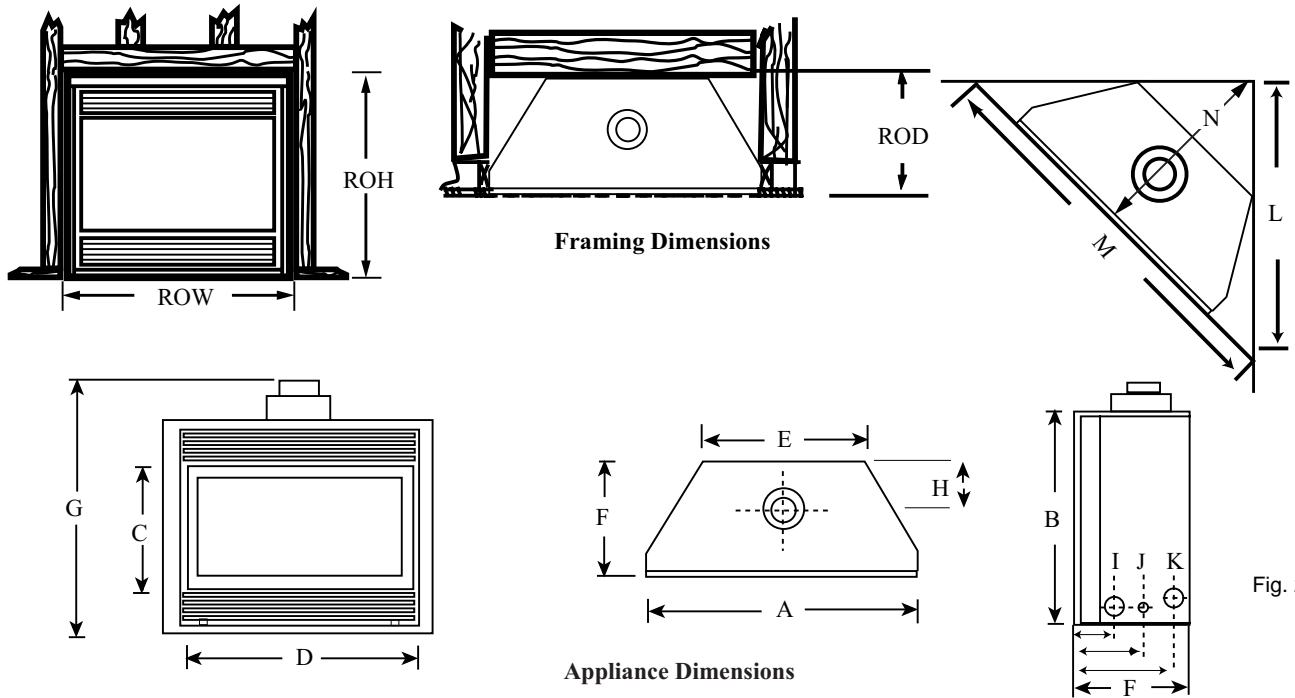

Fig. 2

BHDT36

A	36"	914mm
B	34 1/4"	870mm
C	21"	533mm
D	33"	838mm
E	24"	610mm
F	16"	406mm
G	37 1/4"	946mm
I	7 1/8"	181mm
J	6 3/4"	171mm
K	10"	254mm
L	13 1/2"	343mm
M	39 3/4"	1010mm
N	55 1/4"	1403mm
O	28 1/8"	714mm
ROD	16 1/2"	419mm
ROW	36 1/2"	927mm
ROH	35"	889mm

MANTELS

Depending on the width of the mantel it may be installed higher or lower from the top of the louvre opening. See drawing and chart below for proper installation height of your combustible mantel piece. Non-combustible mantels may be installed at any height above the appliance opening.



When using paint or lacquer to finish the mantel, such paint or lacquer must be heat resistant to prevent discolouration.

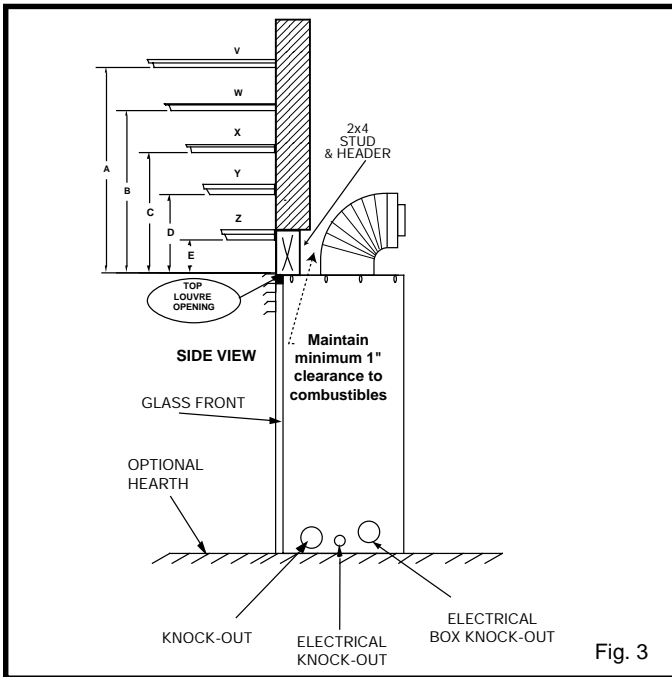

Fig. 3

MANTEL CHART

Ref.	Mantel Depth	Ref.	Mantel From Top Louvre	Mantel Leg from Fireplace Side
V	10" (254 mm)	A	12" (305 mm)	10" (254mm)
W	8" (203 mm)	B	10" (254 mm)	8" (203mm)
X	6" (152 mm)	C	8" (203 mm)	6" (152mm)
Y	4" (101 mm)	D	6" (152 mm)	4" (101mm)
Z	2" (51 mm)	E	4" (101 mm)	2" (51mm)

CLEARANCE TO COMBUSTIBLES

Back	0 mm/0 inches
Side	0 mm/0 inches
Floor	0 mm/0 inches
Top	0 mm/0 inches

FRAMING AND FINISHING

1. Choose fireplace location.
2. Place fireplace into position and secure to floor with 1-1/2" screws, or nails. The holes to secure the fireplace to the floor are located just behind the access door grill on the left and right hand side of the fireplace.
3. Frame in fireplace with a header across the top. It is important to allow for finished face when setting the depth of the frame.
4. Attach fireplace to frame using adjustable frame drywall strips (located behind access door for shipping). Preset depth to suit facing material (adjustable to 1/2" , 5/8" or 3/4" depths). Fig. 4.
5. Screw through slotted holes in drywall strip and then screw into pre-drilled holes on fireplace side. Measure from face of fireplace to face of drywall strip to determine final depth. (Fig. 5 & 6)

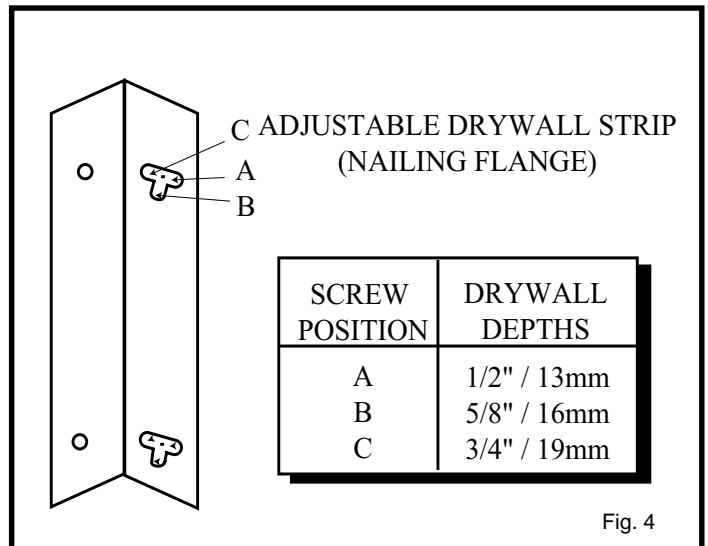

Fig. 4

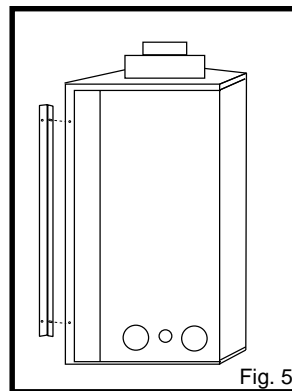

Fig. 5

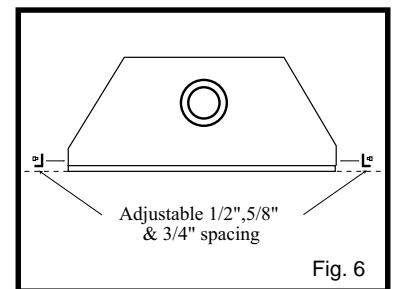

Fig. 6

FINAL FINISHING

Non-combustible materials such as brick and tile can be extended over the face of the unit (**Do not cover louvres or glass door**). If a Trim Kit is going to be installed, brick and tile will have to be installed flush with the side of this appliance.

HEARTH

A hearth is not mandatory but it is recommended for aesthetic purposes. We recommend a non-combustible hearth which does not obstruct louvre opening.



Cold climate installation recommendation: When installing this unit against a non-insulated exterior wall or chase, it is mandatory that the outer walls be insulated to conform to applicable insulation codes.

GAS SPECIFICATIONS

MODEL	FUEL	GAS CONTROL	MAX. INPUT B.T.U.H	MIN. INPUT B.T.U.H.
BHDT36 RN	Natural Gas	Millivolt Hi/Lo	18,000	12,600
BHDT36 RP	Propane Gas	Millivolt Hi/Lo	18,000	13,500

The installation of your Majestic Fireplace must conform with local codes, or in the absence of local codes, with National Fuel Gas Code, ANSI Z223.1 latest edition, or CAN 1 B1-149.1 and .2 Installation Code. (EXCEPTION: Do not derate this appliance for altitude. Maintain the manifold pressure at 3.5 inches W.C. for Natural Gas and 10 inches W.C. for LP gas.)

GAS INLET & MANIFOLD PRESSURES

	NATURAL	LP (Propane)
Input Minimum	4.5" wc	11" wc
Input Maximum	7" wc	13" wc
Manifold Pressure	3.5" wc	10" wc



Do not use this fireplace if any part of it has been under water. Immediately call a qualified service technician to inspect the fireplace and replace any part of the control which has been under water.

CERTIFIED TO

ANSI Z21.88a-1998 / CSA 2.33a-M98
Vented Gas Fireplace Heaters.

GAS LINE INSTALLATION



When purging gas line the front glass must be removed.

The gas pipeline can be brought in through the right side, left side of the appliance as well as the bottom. Knockouts are provided at convenient locations to allow for the gas pipe installation and testing of any gas connection. It is most convenient to bring the gas line in from the right side, as this allows fan installation or removal without disconnecting the gas line.

The gas line connection can be made with properly tinned 3/8" copper tubing, 3/8" rigid pipe or an approved flex connector. Since some municipalities have some additional local codes, it is always best to consult your local authority and the CAN/CGA-B149 (1. or .2) Installation code or for U.S.A Installations consult the current National Fuel Gas Code, ANSI Z223.1



Always check for gas leaks with a mild soap and water solution. **Do not use an open flame for leak testing.**

The gas control is equipped with a captured screw type pressure test point, therefore it is not necessary to provide a 1/8" test point up stream of the control.

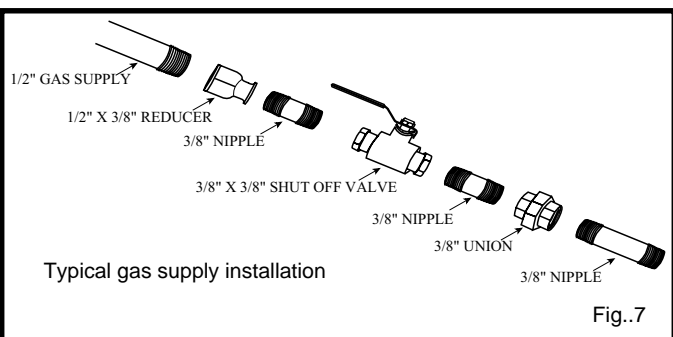

When using copper or flex connector use only approved fittings. **Always provide a union** when using black iron pipe so that gas line can be easily disconnected for burner or fan servicing. See Fig. 7. See gas specification for pressure details and ratings.

The fireplace valve must not be subjected to any test pressures exceeding 1/2 psi. Isolate or disconnect this or any other gas appliance control from the gas line when pressure testing.

REMOTE SWITCH INSTALLATION

1. Thread wire through the electrical knockout located on either side of fireplace.. Do not cut wire or insulation on metal edges. Ensure that wire is protected. Run the other end to a conveniently located wall receptacle box.
2. Attach wire to switch and install switch into receptacle box. Attach cover plate to switch.
3. Connect wiring to gas valve. (Fig. 8/9)

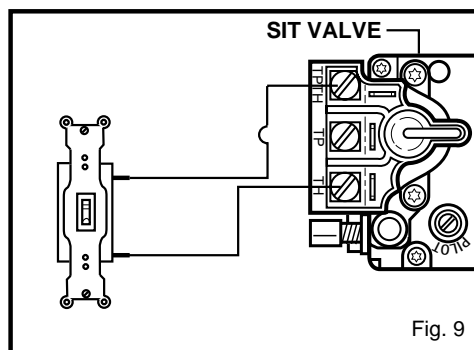
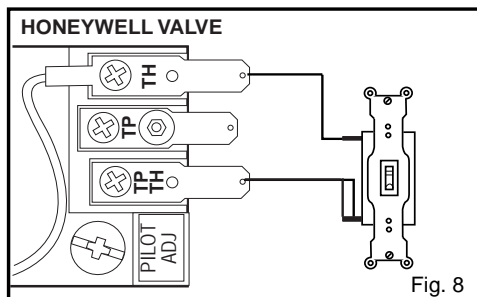

ALTERNATE SWITCH LOCATION:

Remote switch can be installed on either side of the access door. Simply mount the switch to the switch bracket provided. Screw the bracket on either side of the frame, lining up the screws with the pre-punched holes. (Fig. 10)

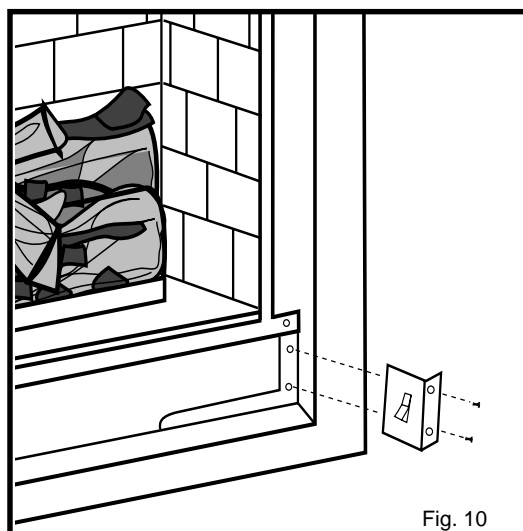

DO NOT WIRE MILLIVOLT REMOTE WALL SWITCH FOR GAS FIREPLACE TO A 120V POWER SUPPLY.



FOR LIGHTING INSTRUCTIONS PLEASE TURN TO PAGE 28.

GENERAL VENTING

Your fireplace is approved to be vented either through the side wall, or vertical through the roof.

- **Only Majestic venting components specifically approved and labelled for this fireplace may be used.**
- **Minimum clearances between vent pipes and combustible materials is one (1") inch (25 mm), except where stated otherwise.**
- Venting terminals shall not be recessed into a wall or siding.
- Horizontal venting must be installed on a level plane without an inclining or declining slope.

There must not be any obstruction such as bushes, garden sheds, fences, decks or utility buildings within 24" from the front of the termination hood.

Do not locate termination hood where excessive snow or ice build up may occur. Be sure to check vent termination area after snow falls, and clear to prevent accidental blockage of venting system. When using snow blowers, make sure snow is not directed towards vent termination area.

Location of Vent Termination

It is imperative that the vent termination be located observing the minimum clearances as shown on this page.

**Check with local codes or in absence of same with CAN/CGA B149 (.1 or .2) Installation Codes (1991) for Canada or for U.S.A. Installations follow the current National Fuel Gas Code, ANSI Z223.1.*

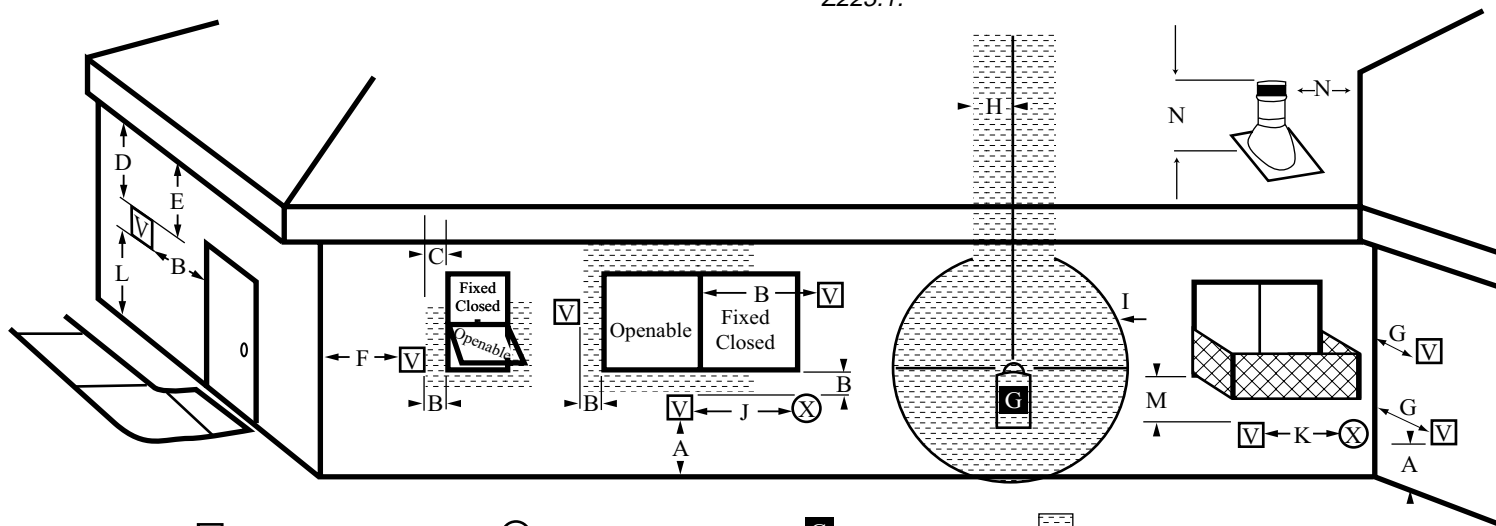

✓ TERMINATION CAP
 X AIR SUPPLY INLET
 G GAS METER
 RESTRICTED AREA (TERMINATION PROHIBITED)

- | | |
|---|--|
| <p>A = clearance above grade, veranda, porch, deck, or balcony [* 12 inches (305mm) minimum]</p> <p>B = clearance to window or door that may be opened 12" (306mm).</p> <p>C = clearance to permanently closed window [minimum 12 inches (305mm) recommended to prevent condensation on window]</p> <p>D = vertical clearance to ventilated soffit located above the termina/ within a horizontal distance of 24 inches (610mm) from the centre-line of the terminal [18 inches (458mm) minimum]</p> <p>E = clearance to unventilated soffit [12 inches (305mm) minimum]</p> <p>F = clearance to outside corner see next page</p> <p>G = clearance to inside corner see next page</p> <p>H = * not to be installed above a meter/regulator assembly within 36 inches (914mm) horizontally from the centre-line of the regulator</p> | <p>I = clearance to service regulator vent outlet [*72 inches (1828mm) minimum]</p> <p>J = clearance to non-mechanical air supply inlet to building or the combustion air inlet to any other fireplace [*12 inches (305mm) minimum]</p> <p>K = clearance to a mechanical air supply inlet [* 72 inches (1828mm) minimum]</p> <p>L = † clearance above paved side-walk or a paved driveway located on public property [*84 inches (2133mm) minimum]</p> <p>M = clearance under veranda, porch, deck [*12 inches (305mm) minimum ‡]</p> <p>N = Clearance above a roof shall extend a minimum of 24" (610mm) above the highest point when it passes through the roof surface, and any other obstruction within a horizontal distance of 18" (450mm).</p> |
|---|--|

† a vent shall not terminate directly above a side-walk or paved driveway which is located between two single family dwellings and serves both dwellings *

‡ only permitted if veranda, porch, deck, is fully open on a minimum 2 sides beneath the floor *

* as specified in CAN/CGA B149 (.1 or .2) Installation Codes (1991) for Canada or for U.S.A. Installations follow the current National Fuel Gas Code, ANSI Z223.1.

Note: Local codes or regulations may require different clearances.

Termination Clearances

Termination clearances for buildings with combustible and noncombustible exteriors.

Inside Corner

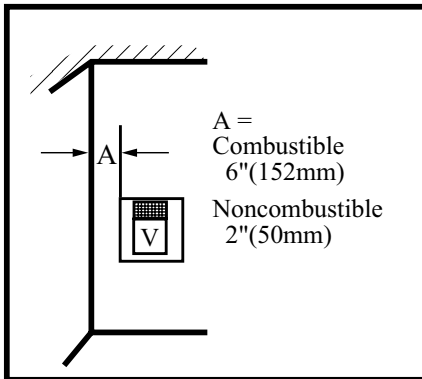

Outside Corner

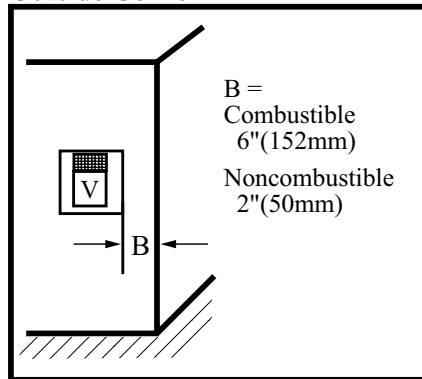

Recessed Location

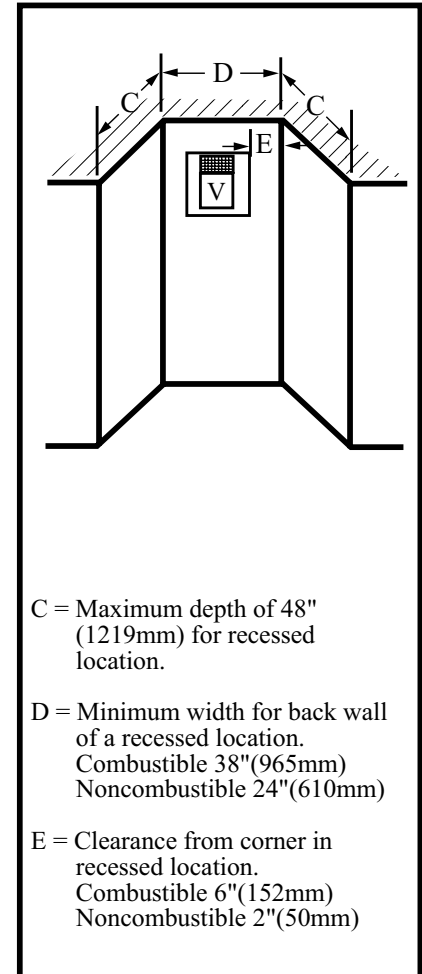
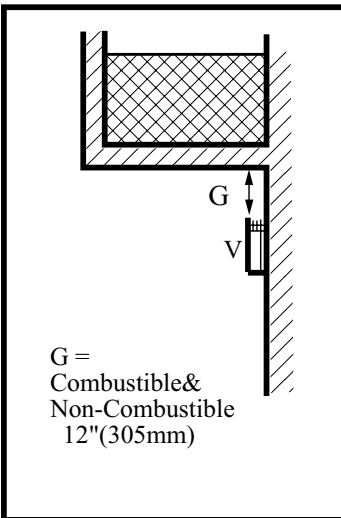
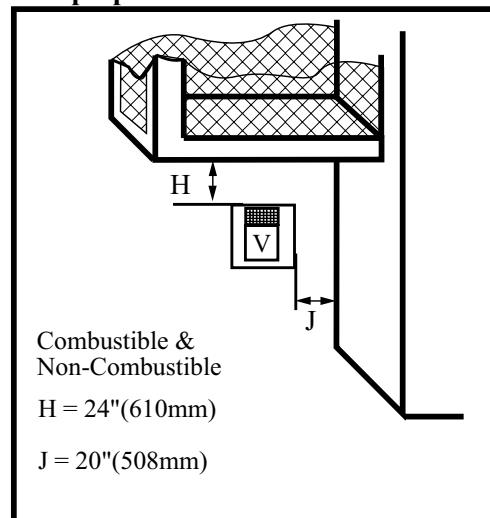

Fig. 11

Balcony - with no side wall



Balcony - with perpendicular side wall



GENERAL INFORMATION ON ASSEMBLING THE VENT PIPES WITH CRIMPED ENDS

Before joining elbows and pipes apply a bead of high temperature sealant to crimped end of elbow or pipe. (Fig.12)

Join pipes and secure joints with three (3) sheetmetal screws. (See Fig. 12) Wipe off excess sealant.

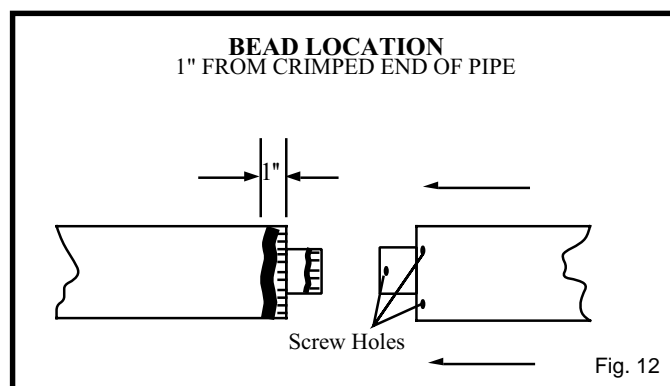
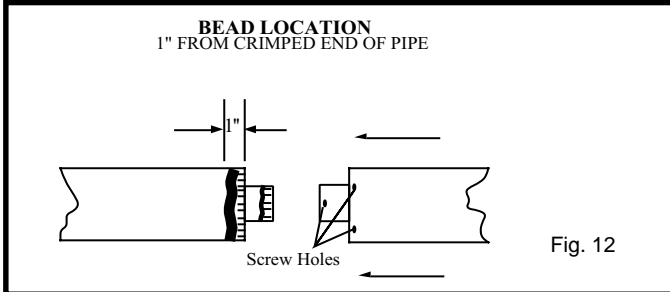

Fig. 12

GENERAL INFORMATION ON ASSEMBLING THE VENT PIPES WITH CRIMPED ENDS

Before joining elbows and pipes apply a bead of high temperature sealant to crimped end of 4" and 7" elbow or pipe. (Fig. 12)

Join pipes and secure joints with three (3) sheetmetal screws. (See Fig. 12) Wipe off excess sealant.



IMPORTANT Minimum clearance between vent pipes and combustible materials is one (1") inch (25 mm) on bottom, sides and top.



Only Majestic venting components specifically approved and labelled for this fireplace may be used.

VERTICAL SIDEWALL APPLICATIONS



Vent Starter Kit 7DVSK must be used in Vertical Sidewall installations.

Since it is very important that the venting system maintain its balance between the combustion air intake and the flue gas exhaust, certain limitations as to vent configurations apply and must be strictly adhered to.

The graph showing the relationship between vertical and horizontal side wall venting will help to determine the various vent lengths allowable. Fig. 17.



Minimum clearance between vent pipes and combustible materials is one (1") inch (25 mm) on top, bottom and sides unless otherwise noted.



When vent termination exits through foundation less than 20" below siding outcrop, the vent pipe must flush up with the siding. A 7DVSS must also be used.

It is always best to locate the fireplace in such a way that minimizes the number of offsets and horizontal vent length.



The horizontal vent run refers to the total length of vent pipe from the flue collar of the fireplace to the face of the outer wall.



Horizontal plane means no vertical rise exists on this portion of the vent assembly.



For some installations, it may be desirable to have some amount of the horizontal vent run immediately after the fireplace. A vertical rise must be used but can be located anywhere in the vent system, to meet the perimeters identified in the venting graph.

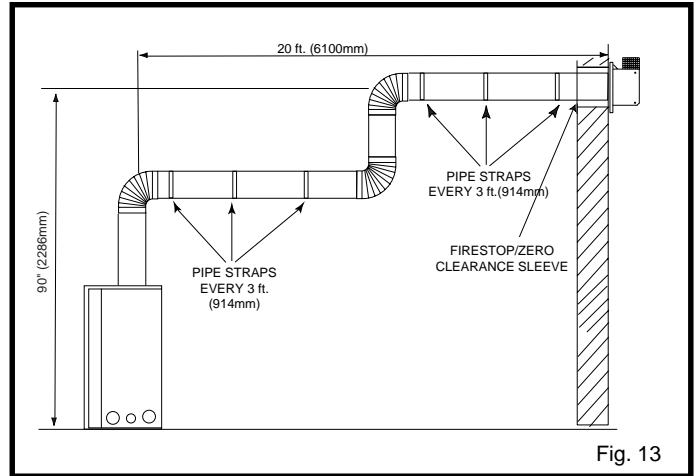

The maximum number of 90 degree elbows per side wall installation is three (3).

The maximum number of 45 degree elbows permitted per side wall installation is two (2). These elbows can be installed in either the vertical or horizontal run.

The maximum horizontal vent length is 36" (914mm) when 90° elbow is installed directly onto fireplace.

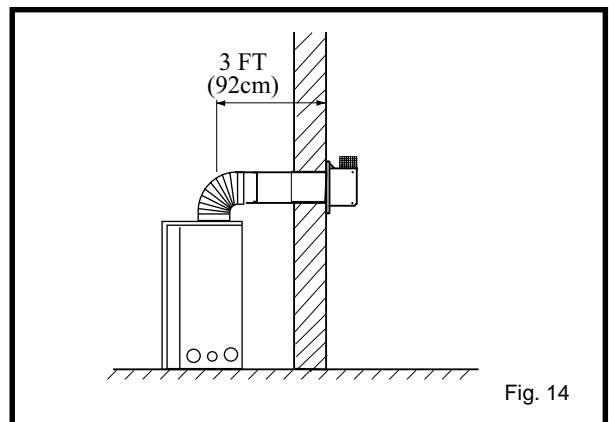

For each 45 degree elbow installed in the horizontal run (while maintaining a constant horizontal plane), the length of the horizontal run **MUST** be reduced by 18" (457mm). This does not apply if the 45 degree elbows are installed on the vertical part of the vent system.



If a 90 degree elbow is used in the horizontal vent run (level height maintained) the maximum horizontal vent length is reduced by 36 inches. Fig. 15. This does not apply if the 90 degree elbows are used to increase or redirect a vertical rise.

The maximum number of elbow degrees in a system is 270°.

Sample:	1	-	90°
	2	-	45°
	3	-	45°
	4	-	90°
	Total		270°

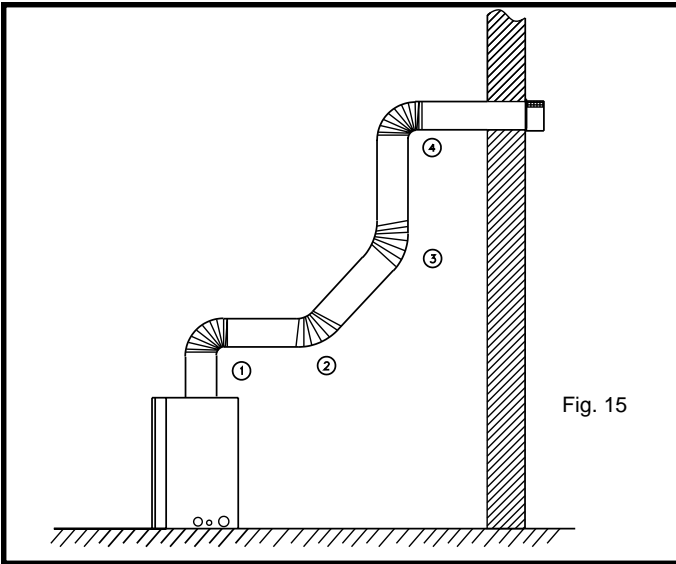

Example: According to the vent chart the maximum horizontal vent length is 20' when the vertical height is 7.5' from fireplace base height. If one 90 degree elbow is required in the horizontal vent it must be reduced to 17'.

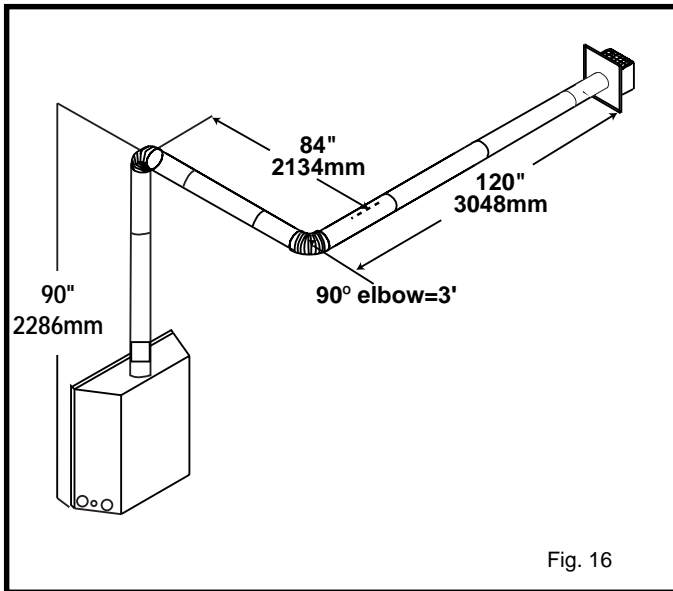

HOW TO USE THE VENT GRAPH

1. Determine the height of the centre of the horizontal vent pipe exiting through the outer wall. Using this dimension on the Sidewall Vent Graph (Fig. 17), locate the point it intersects with the slanted graph line.
2. From the point of this intersection, draw a vertical line to the bottom of the graph.
3. Select the indicated dimension, and position the fireplace in accordance with same.

EXAMPLE A:

If the vertical dimension from the floor of the unit is 11 feet (3352mm) the horizontal run to the face of the outer wall must not exceed 14 feet (4267mm).

EXAMPLE B:

If the vertical dimension from the floor of the unit is 7 feet (2133mm), the horizontal run to the face of the outer wall must not exceed 8-1/2 feet (2590mm).

VERTICAL SIDEWALL VENTING GRAPH (Dimensions in Feet)

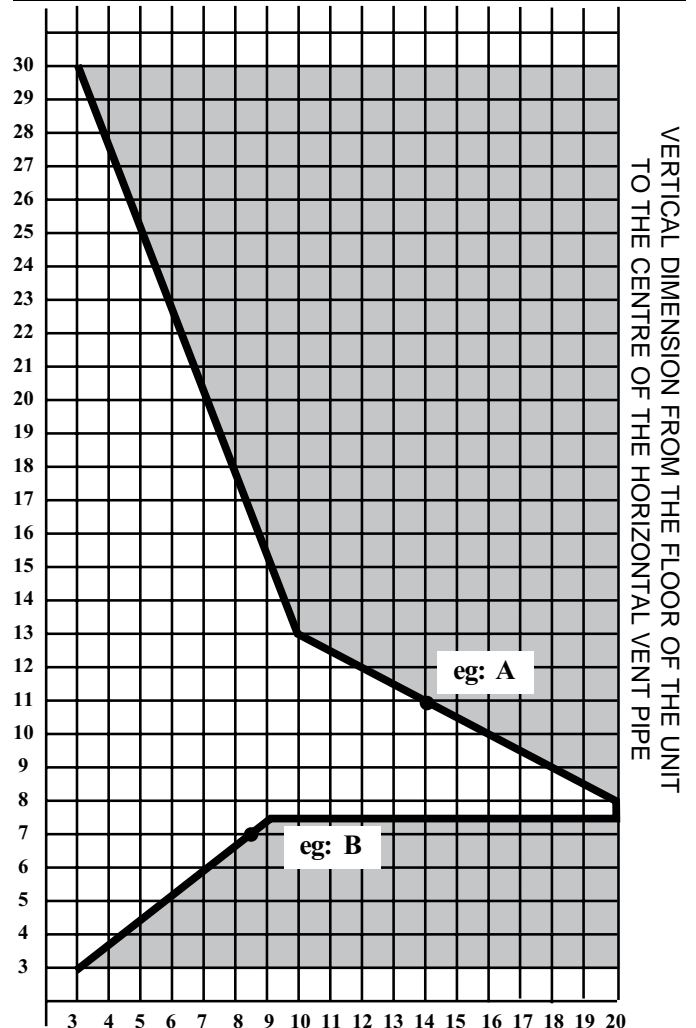

Fig. 17

SEE PAGE 14 FOR VENTING REQUIREMENTS FOR SNORKELS.

VERTICAL SIDEWALL INSTALLATION

STEP 1

Locate vent opening on the wall. It may be necessary to first position the fireplace and measure to obtain hole location. Depending on whether the wall is combustible or non-combustible, cut opening to size.

(For combustible walls first frame in opening).

VERTICAL SIDEWALL APPLICATION

Vent Opening — Combustible Wall Fig. 18

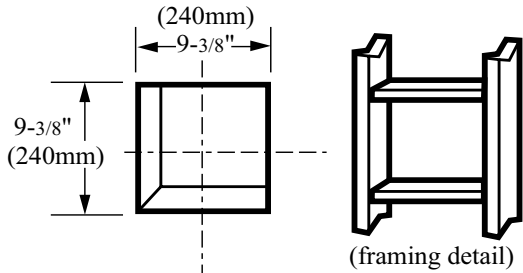

Vent Opening — Noncombustible Wall Fig. 19

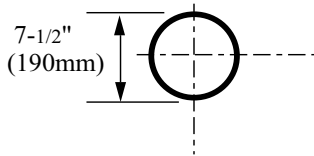

COMBUSTIBLE WALLS (Fig. 18): Cut a 9-3/8"H x 9-3/8"W (240 mm x 240 mm) hole through the exterior wall and frame as shown.

NON-COMBUSTIBLE WALLS (Fig. 19): Hole opening must be 7.5" (190 mm) in diameter.

STEP 2

Fig. 20. Measure wall thickness and cut adjustable zero clearance sleeve parts to proper length (MAXIMUM 12"/305mm). Adjust sleeve to minimum (9-3/8" x 9-3/8") and attach to firestop with #8 sheet metal screws (supplied). Install firestop assembly.



Zero clearance sleeve is only required for combustible walls.

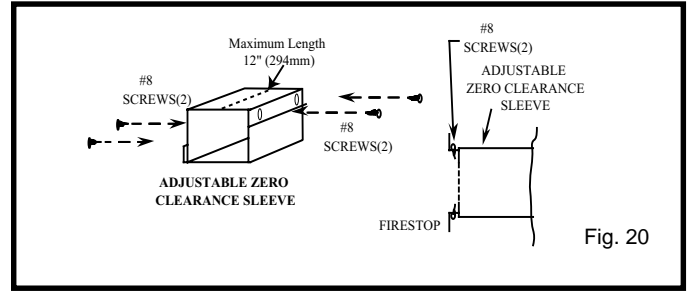
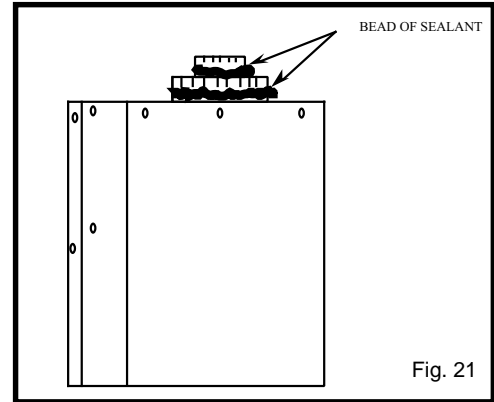

Fig. 20

STEP 3

(Fig. 21) Apply a bead of high temperature sealant to the inner and outer flue collars of the fireplace and using appropriate venting component(s) attach to fireplace with three (3) screws. Follow with the installation of the inner and outer elbow. Again secure joints with three (3) sheet metal screws. Wipe off any excess high temperature sealant.



STEP 4

(Fig. 22) Measure the horizontal length requirement including a 2" (50mm) overlap, i.e. from the elbow to the outside wall finish plus 2" (or the distance required if installing a second 90° elbow).



Always install horizontal venting on a level plane.

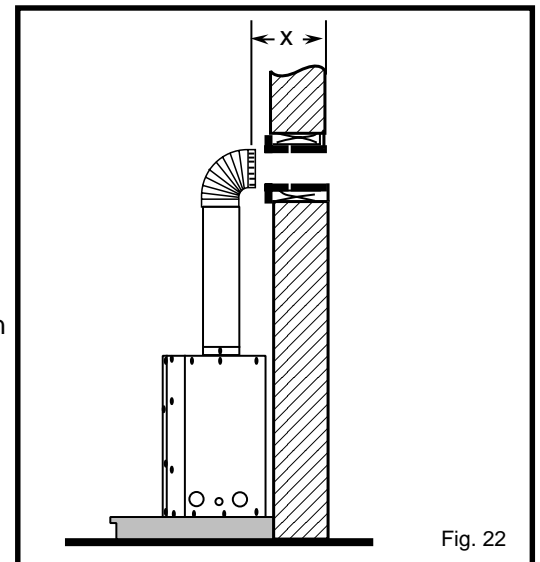

STEP 5

(Fig. 23) Use the appropriate length of pipe section – telescopic or fixed – and install. The 20" (508mm) section of pipe which goes through the wall is packaged with the 7DVSK kit, and can be cut to suit if necessary.



Sealing vent pipe and firestop gaps with high-temperature sealant will restrict cold air being drawn in around fireplace.

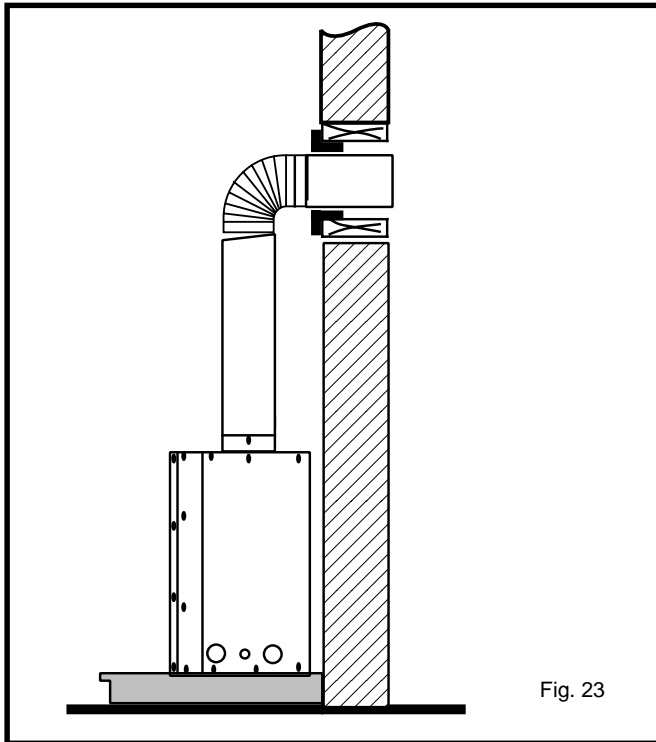

Fig. 23

STEP 6

(Fig. 24) Apply high temperature sealant to 4" and 7" collars one inch away from crimped end. Guide the vent termination 4" and 7" collars into their respective vent pipes. Double check that the vent pipes overlap the collars by 2" (50mm). Secure the termination to the wall with screws provided and caulk around the wall plate to weatherproof.

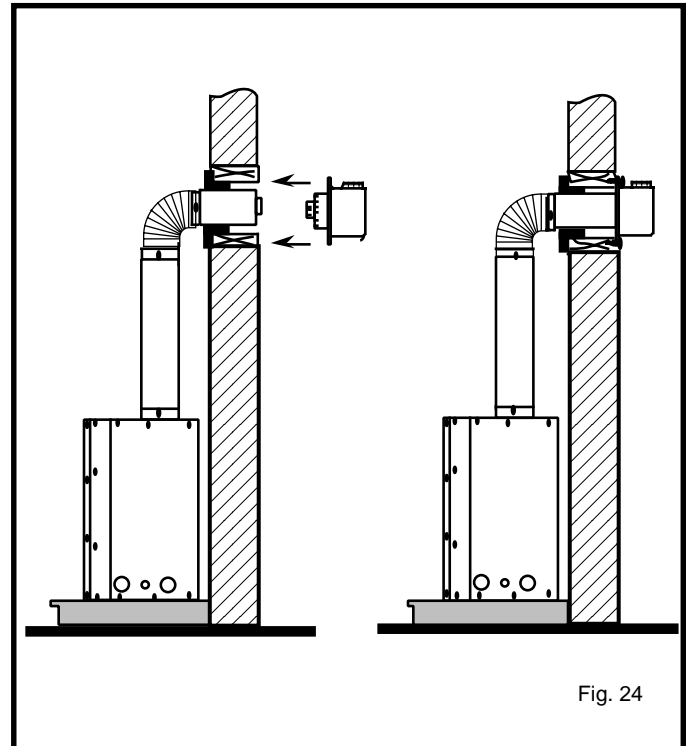

Fig. 24

STEP 7

Support the horizontal pipes every 36 inches (914mm) with metal pipe straps. Make sure that the horizontal vent pipe is installed on a level horizontal plane.

STEP 8

Recheck the fireplace to make sure that it is levelled, properly positioned, and nailed or screwed to the floor.

If applied, the fireplaces adjustable frame drywall strips (nailing flanges) should be fastened. See "Framing & Finishing."

BELOW GRADE INSTALLATIONS

When it is not possible to meet the required vent terminal clearances of 12 inches (305mm) above grade level a model #7DVSKS vent kit is required. It allows installation depth of down to 7 inches (178mm) below grade level. The 7 inches is measured from the centre of the horizontal vent pipe as it penetrates through the wall.



If venting system is installed below ground, we recommend a window well with adequate and proper drainage.

Ensure sidewall venting clearances are observed.



The maximum horizontal run with 24" (610mm) vertical rise is 36" (914mm) from the back of the fireplace to the face of the exterior wall. See vent graph (Fig. 17) for extended horizontal run if the vertical exceeds 24" (610mm).

1. Establish vent hole through the wall. See page 12
2. Remove soil to a depth of approximately 16" (406mm) below base of snorkel. Install window well (not supplied). Refill hole with 12" (305mm) of coarse gravel leaving a clearance of approximately 4" (100mm) below snorkel. (Fig. 25)
3. Install vent system. See page 12/13, Steps 2 through 5.
4. Ensure a watertight seal is made around the vent pipe coming through the wall.
5. Apply high temperature sealant caulking (supplied) around the 4 and 7 inch 7DVSKS's snorkel collars.
6. Slide into vent pipe and secure to the wall.
7. Level the soil so as to maintain a 4" (100mm) clearance below snorkel (Fig. 25).

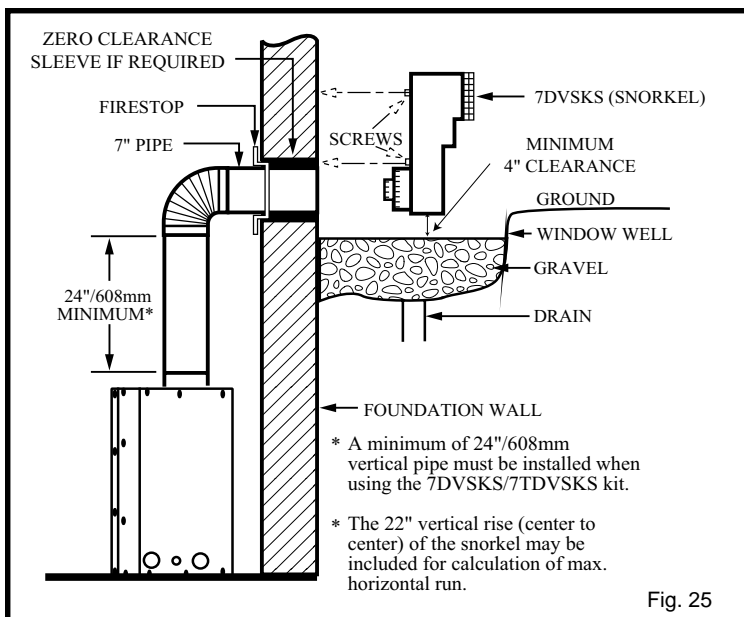

DO NOT BACK FILL AROUND SNORKEL. SOIL SHOULD NOT BE LESS THAN 4" (100mm) BELOW SNORKEL.

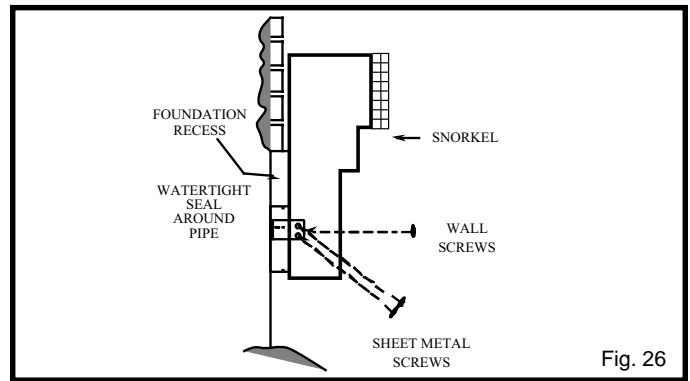

If the foundation is recessed, use recess brackets (not supplied) for securing lower portion of the snorkel. Fasten brackets to wall first and then secure to snorkel with self drilling #8 x 1/2 sheet metal screws. It will be necessary to extend vent pipes out as far protruding wall face (Fig. 26).

VERTICAL THROUGH THE ROOF APPLICATIONS

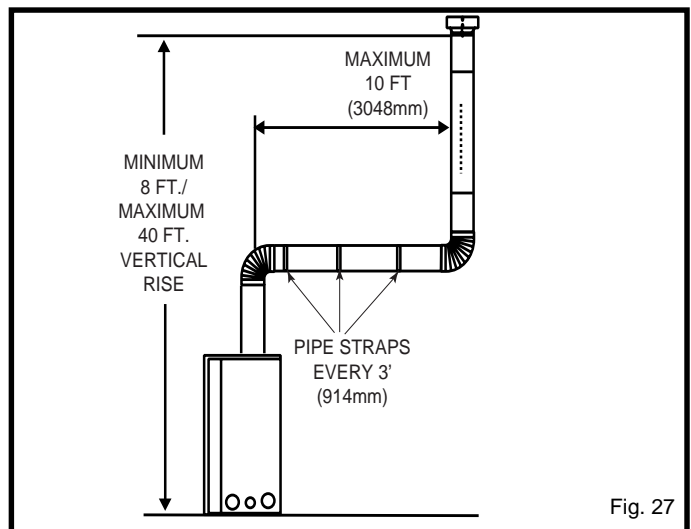

This Gas Fireplace has been approved for,

- a) Vertical installations up to 40 feet (12 metres) in height. Up to a 10 ft.(3048mm) horizontal vent run can be installed within the vent system using a maximum of three 90° elbows.
- b) Up to two 45° elbows may be used within the horizontal run. For each 45° elbow used on the horizontal level the maximum horizontal length must be reduced by 18 inches (457mm).

Example: Maximum horizontal length

0	-	45° elbows	10 ft. (3048mm)
1	-	45° elbows	8.5 ft. (2590mm)
2	-	45° elbows	7 ft. (2133mm)

- c) A minimum of an 8 ft. vertical rise.
 - d) Two sets of 45 degree elbow offsets within these vertical installations. From 0 to a maximum of 8 ft. (2438mm) a vent pipe can be used between elbows. (Fig. 28)
 - e) 7DVCS must be used to support offsets. (Fig. 29)
- This application will require that you first determine the roof pitch and use the appropriate 7DVSKV (A,B or F). (see Venting Components, page 16)

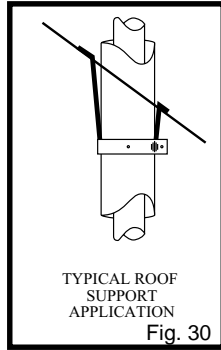
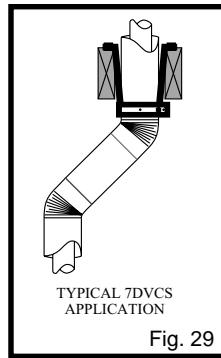
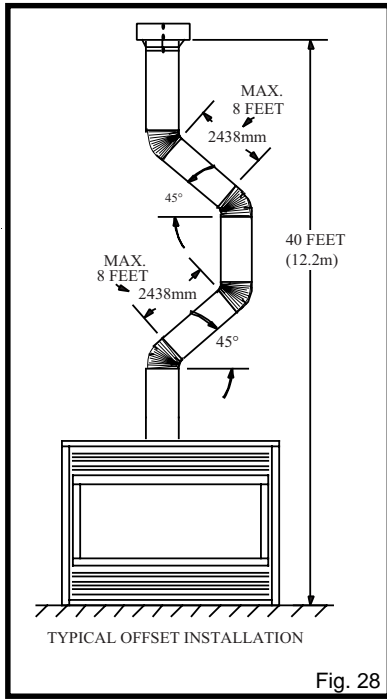

VERTICAL THRU THE ROOF INSTALLATION

1. Locate your fireplace.
2. Plumb to centre of the (4") collar from ceiling above and mark position.
3. Cut opening equal to 9-3/8" x 9-3/8" (240 mm x 240 mm).
4. Proceed to plumb for additional openings through the roof. In all cases, the opening must provide a minimum of 1 inch clearance to the vent pipe, i.e., the hole must be a minimum of 9-3/8" x 9-3/8" (240 mm x 240 mm).
5. Place firestop(s) 7DVFS into position and secure. (Fig. 32)
6. Install roof support (Fig. 30) and roof flashing making sure upper flange of flashing is below the shingles. (Fig. 33)
7. Install appropriate pipe sections until above the flashing. (See Fig. 31 for #'s 7, 8 and 9).
8. Install storm collar and seal around the pipe.
9. Add additional vent lengths for proper height.
10. Apply high temperature sealant to 4" and 7" collars of vent termination and install.

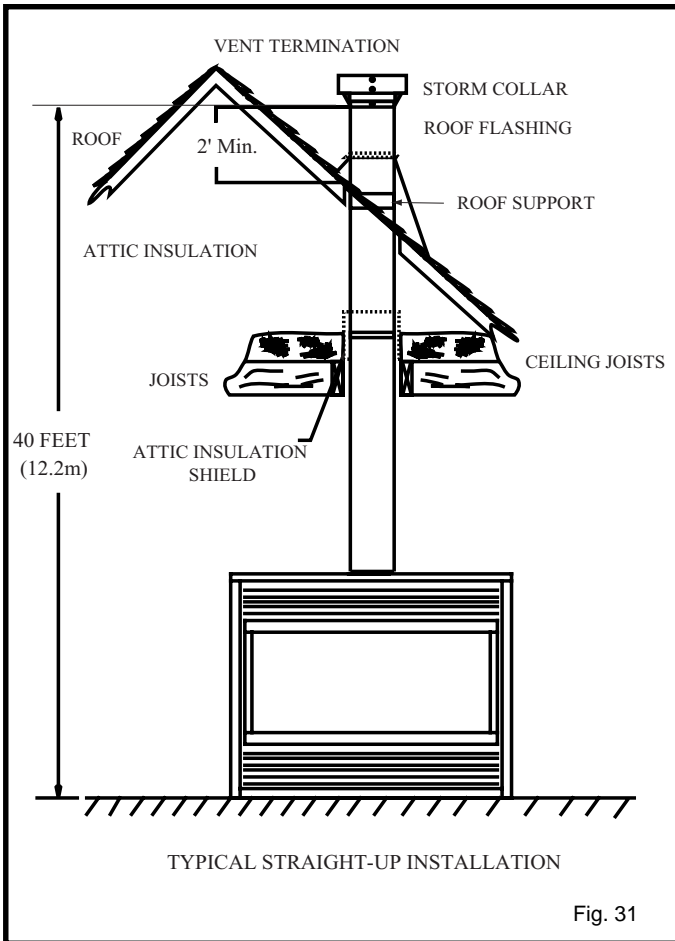

Clearance above a roof shall extend a minimum of 24" (610mm) above the highest point when it passes through the roof surface, and any other obstruction within a horizontal distance of 18" (450mm).

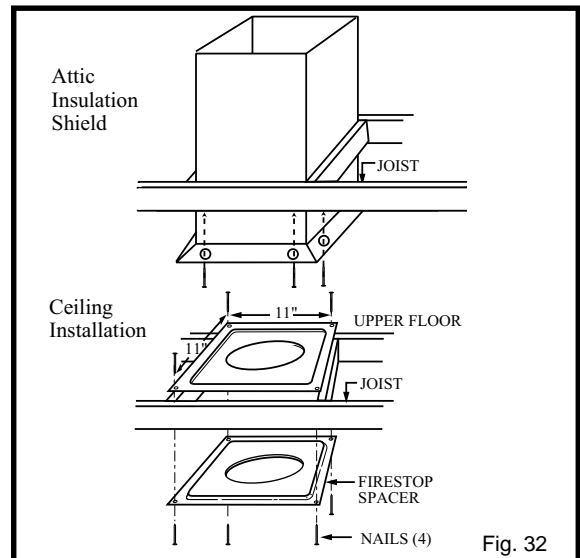
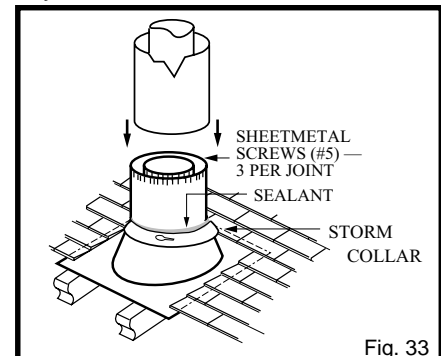

Fig. 32 If there is a room above ceiling level, firestop spacer must be installed on both the bottom and the top side of the ceiling joists. If an attic is above ceiling level a 7DVAIS (Attic Insulation Shield) must be installed.



Fig. 33. The enlarged ends of the vent section always face downward.

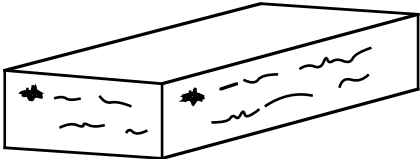
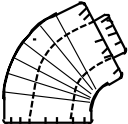
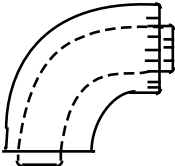
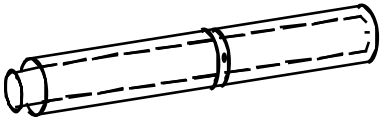
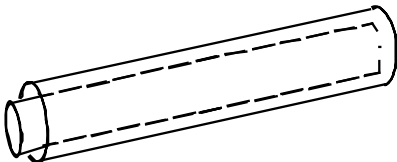
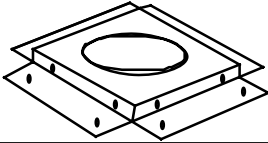
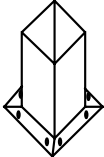
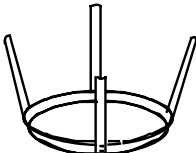
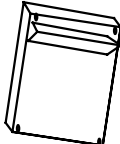

CRIMPED ENDS VENTING COMPONENTS

	<p>Starter Kit - Model 7DVSK - Sidewall Venting</p> <p>Starter Kit - Model 7DVSKV - Vertical Venting for 7DVSKV-A order 1/12 to 6/12 roof pitch for 7DVSKV-B order 7/12 to 12/12 roof pitch for 7DVSKV-F order flat roof</p> <p>Starter Kit - Model 7DVSKS - Snorkel Kit for Below Grade Installation</p>
	<p>45° elbow kit 7DVT45 for Vertical Installation Offsets</p>
	<p>90° transition elbow kit 7DVRT90 for Vertical Sidewall Applications or thru-the-roof.</p>
	<p>Telescopic vent sections</p> <p>7DVP610 - 6" to 10" adjustable length 7DVP1018 - 10" to 18" adjustable length 7DVP1834 - 18" to 34" adjustable length 7DVP3466 - 34" to 66" adjustable length</p>
	<p>Pipe sections for vertical or horizontal venting</p> <p>Model 7DVP8" - 4 per box Model 7DVP12" - 4 per box Model 7DVP24" - 4 per box Model 7DVP36" Model 7DVP48"</p>
	<p>Firestop Spacer Model 7DVFS</p>
	<p>Attic Insulation Shield Model 7DVAIS</p>
	<p>Vertical/Horizontal Combination Offset Support Model 7DVCS</p>
	<p>7DVSS Siding Shield (to protect siding)</p>

GENERAL INFORMATION ON ASSEMBLING THE TWIST LOCK VENT PIPES

When using CFM Majestic twist lock pipe it is not necessary to use silicone to seal the twist lock joints. The only areas that need silicone are the collars on the fireplace, the telescoping pipe (if used) and the horizontal termination connection (when necessary).

To join the pipes together, simply align the beads of the male end with the grooves of the female end and while joining the two together, twist the pipe until the flange on the female end touches the external bead on the male end. Secure the joints with three sheet metal screws.

To make easier to assembly, we suggest putting lubricant (vaseline or similar) on the male end of the twist lock pipe.

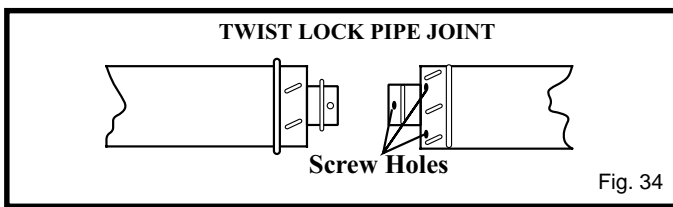

! Crimped pipe and new twist lock pipe.

It is possible to use CFM Majestic 4" & 7" direct vent crimped pipe and elbows in your system, with the new CFM Majestic 4" & 7" Direct Vent Twist Lock Pipe.

You must use the crimped pipe first in the system off the appliance.

1. Install expanded end of crimped pipe or elbow onto the 4" & 7" collars off the fireplace with high temperature sealant and 3 screws.
2. If you wish to continue your system with your 4" & 7" crimped pipe or elbow apply high temperature sealant on crimped end of pipe at 2" in from end and fasten the next pipe with 3 sheet metal screws.
3. When you wish to continue your system with the New Twist Lock pipe or elbow, apply high temperature sealant on crimped end of pipe at 1-1/2" from end, and slip the female end of the twist lock pipe over the crimped end of the pipe and secure with 3 sheet metal screws. Continue the installation with twist lock pipe placing the female end over the male end and fastening with 3 sheet metal screws.

You do not have to use high temperature sealant when using twist lock pipe between the female and male ends of the twist lock.

- Except on:
1. Adjustable lengths (telescoping joint only)
 2. Crimped collar on existing fireplaces.
 3. Terminations where required.

VERTICAL SIDEWALL APPLICATIONS



Vent Starter Kit 7TDVSK must be used in Vertical Sidewall installations.

Since it is very important that the venting system maintain its balance between the combustion air intake and the flue gas exhaust, certain limitations as to vent configurations apply and must be strictly adhered to.

The graph showing the relationship between vertical and horizontal side wall venting will help to determine the various vent lengths allowable. Fig. 39.



Minimum clearance between vent pipes and combustible materials is one (1") inch (25 mm) on top, bottom and sides unless otherwise noted.



When vent termination exits through foundation less than 20" below siding outcrop, the vent pipe must flush up with the siding. A 7DVSS must also be used.

It is always best to locate the fireplace in such a way that minimizes the number of offsets and horizontal vent length.



The horizontal vent run refers to the total length of vent pipe from the flue collar of the fireplace to the face of the outer wall.



Horizontal plane means no vertical rise exists on this portion of the vent assembly.



For some installations, it may be desirable to have some amount of the horizontal vent run immediately after the fireplace. A vertical rise must be used but can be located anywhere in the vent system, to meet the perimeters identified in the venting graph.

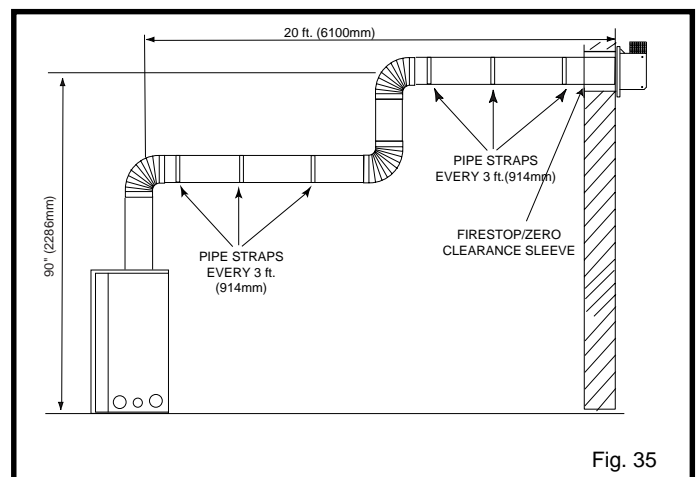

The maximum number of 90 degree elbows per side wall installation is three (3).

The maximum number of 45 degree elbows permitted per side wall installation is two (2). These elbows can be installed in either the vertical or horizontal run.

The maximum horizontal vent length is 36" (914mm) when 90° elbow is installed directly onto fireplace.

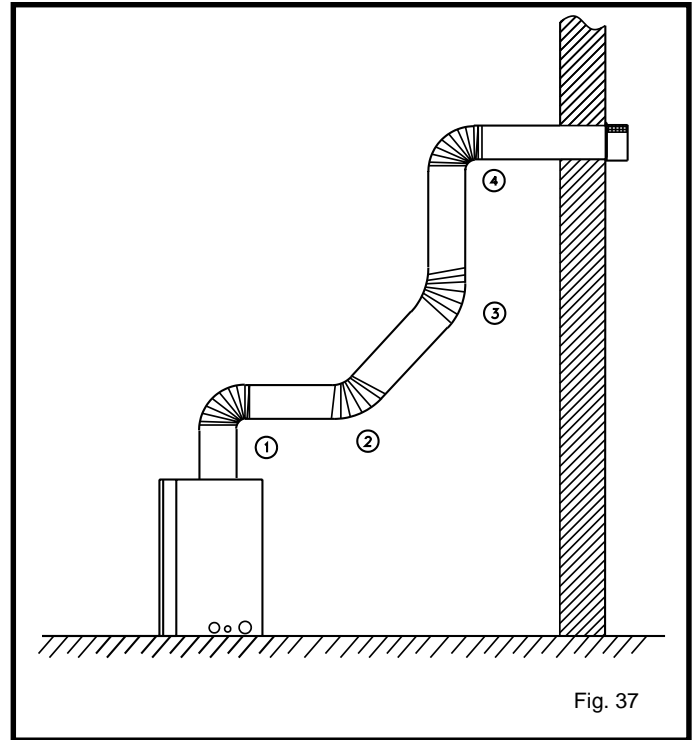
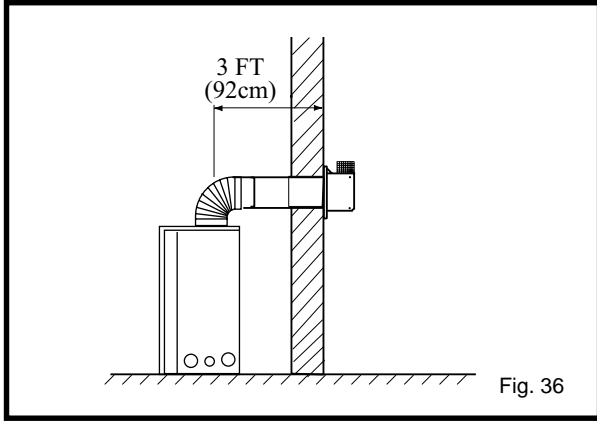

For each 45 degree elbow installed in the horizontal run (while maintaining a constant horizontal plane), the length of the horizontal run MUST be reduced by 18" (457mm). This does not apply if the 45 degree elbows are installed on the vertical part of the vent system.



If a 90 degree elbow is used in the horizontal vent run (level height maintained) the maximum horizontal vent length is reduced by 36 inches. Fig. 36. This does not apply if the 90 degree elbows are used to increase or redirect a vertical rise.



The maximum number of elbow degrees in a system is 270°.

Sample:	1	-	90°
	2	-	45°
	3	-	45°
	4	-	90°
	Total		270°

Example: According to the vent chart the maximum horizontal vent length is 20' when the vertical height is 7.5' from fireplace base height. If one 90 degree elbow is required in the horizontal vent it must be reduced to 17'.

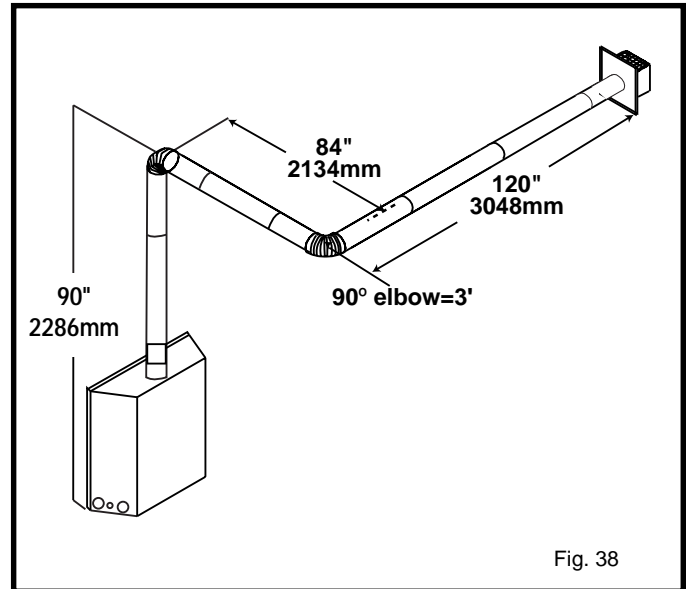

HOW TO USE THE VENT GRAPH

1. Determine the height of the centre of the horizontal vent pipe exiting through the outer wall. Using this dimension on the Sidewall Vent Graph (Fig. 39), locate the point it intersects with the slanted graph line.
2. From the point of this intersection, draw a vertical line to the bottom of the graph.
3. Select the indicated dimension, and position the fireplace in accordance with same.

EXAMPLE A:

If the vertical dimension from the floor of the unit is 11 feet (3352mm) the horizontal run to the face of the outer wall must not exceed 14 feet (4267mm).

EXAMPLE B:

If the vertical dimension from the floor of the unit is 7 feet (2133mm), the horizontal run to the face of the outer wall must not exceed 8-1/2 feet (2590mm).

VERTICAL SIDEWALL VENTING GRAPH (Dimensions in Feet)

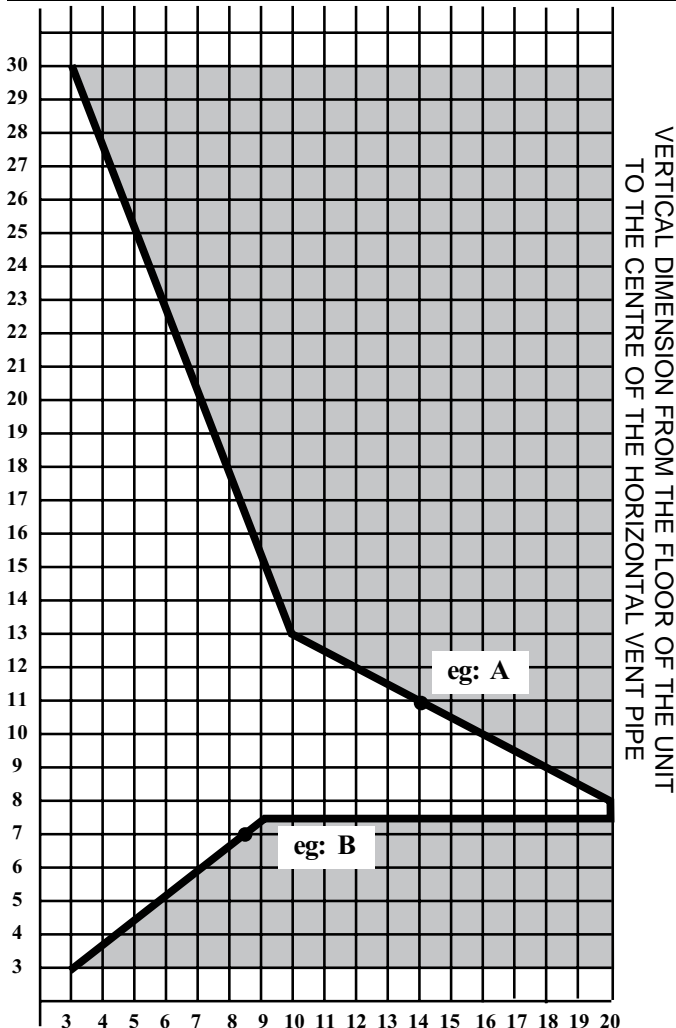

Fig. 39

SEE PAGE 21 FOR VENTING
REQUIREMENTS FOR SNORKELS.

VERTICAL SIDEWALL INSTALLATION

STEP 1

Locate vent opening on the wall. It may be necessary to first position the fireplace and measure to obtain hole location. Depending on whether the wall is combustible or non-combustible, cut opening to size.

(For combustible walls first frame in opening).

VERTICAL SIDEWALL APPLICATION

Vent Opening — Combustible Wall Fig. 40

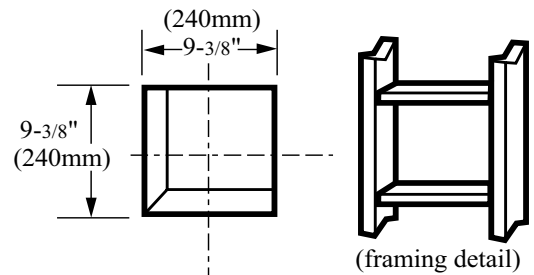

Vent Opening — Noncombustible Wall Fig. 41

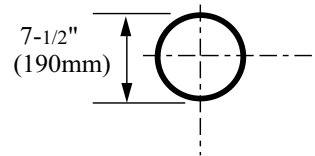

COMBUSTIBLE WALLS (Fig. 40): Cut a 9-3/8"H x 9-3/8"W (240 mm x 240 mm) hole through the exterior wall and frame as shown

NON-COMBUSTIBLE WALLS (Fig. 41): Hole opening must be 7.5" (190 mm) in diameter.

STEP 2

Fig. 42. Measure wall thickness and cut adjustable zero clearance sleeve parts to proper length (MAXIMUM 12"/305mm). Adjust sleeve to minimum (9-3/8" x 9-3/8") and attach to firestop with #8 sheet metal screws (supplied). Install firestop assembly.



Zero clearance sleeve is only required for combustible walls.

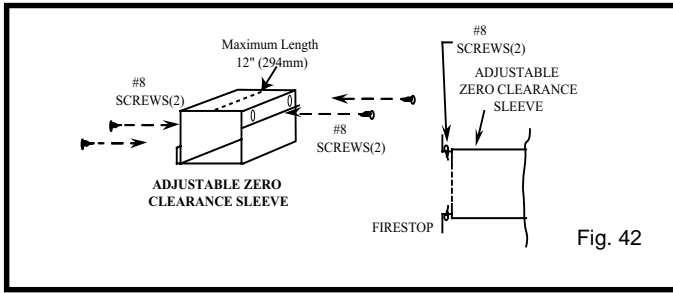
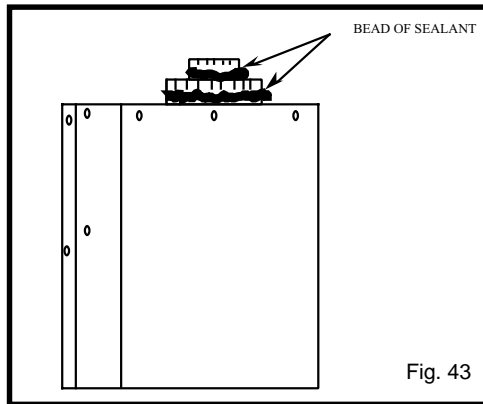

Fig. 42

STEP 3

(Fig. 43) Apply a bead of high temperature sealant to the inner and outer flue collars of the fireplace and using appropriate venting component(s) attach to fireplace with three (3) screws. Follow with the installation of the inner and outer elbow. Again secure joints with three (3) sheet metal screws. Wipe off any excess high temperature sealant.



STEP 4

(Fig. 44) Measure the horizontal length requirement including a 2" (50mm) overlap, i.e. from the elbow to the outside wall finish plus 2" (or the distance required if installing a second 90° elbow).



Always install horizontal venting on a level plane.

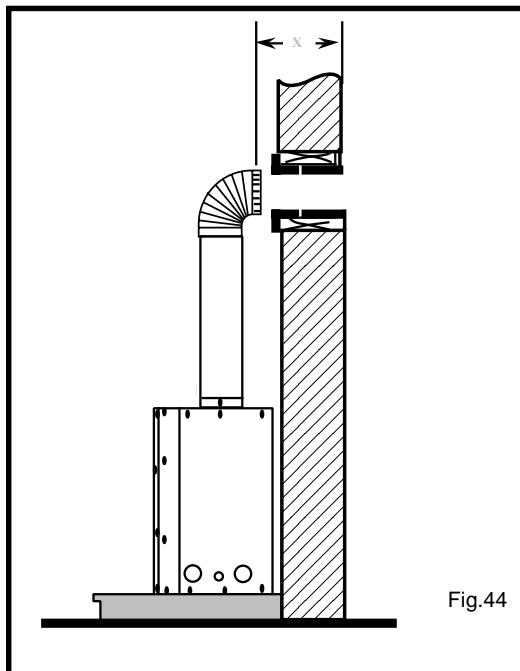

STEP 5

(Fig. 45) Use the appropriate length of pipe section – telescopic or fixed – and install. The 20" (508mm) section of pipe which goes through the wall is packaged with the 7TDVSK kit, and can be cut to suit if necessary.



Sealing vent pipe and firestop gaps with high-temperature sealant will restrict cold air being drawn in around fireplace.

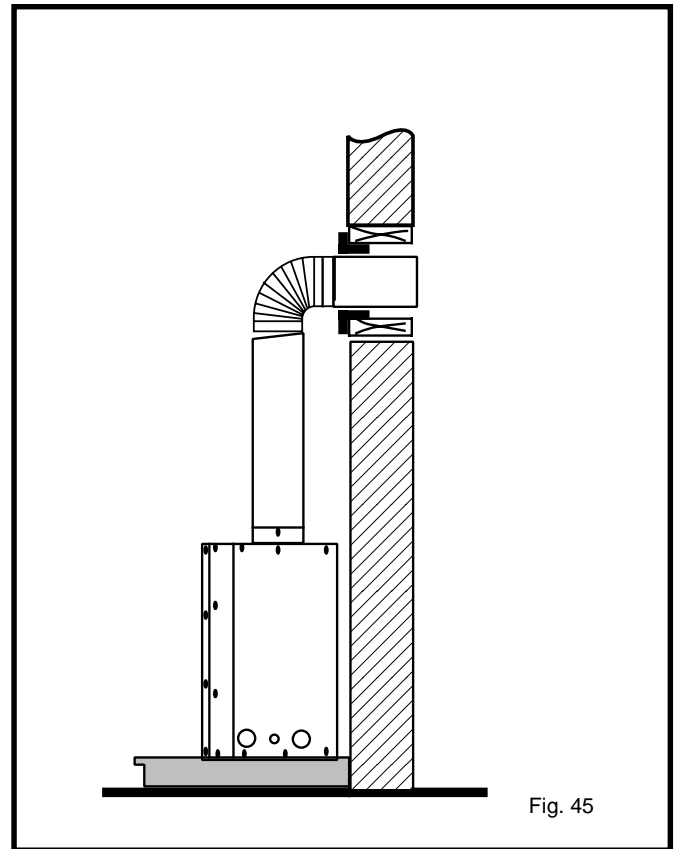

STEP 6

(Fig. 46) Apply high temperature sealant to 4" and 7" collars one inch away from crimped end. Guide the vent termination 4" and 7" collars into their respective vent pipes. Double check that the vent pipes overlap the collars by 2" (50mm). Secure the termination to the wall with screws provided and caulk around the wall plate to weatherproof.

BELOW GRADE INSTALLATIONS

When it is not possible to meet the required vent terminal clearances of 12 inches (305mm) above grade level a model 7TDVSKS vent kit is required. It allows installation depth of down to 7 inches (178mm) below grade level. The 7 inches is measured from the centre of the horizontal vent pipe as it penetrates through the wall.



If venting system is installed below ground, we recommend a window well with adequate and proper drainage.

Ensure sidewall venting clearances are observed.



The maximum horizontal run with 24" (610mm) vertical rise is 36" (914mm) from the back of the fireplace to the face of the exterior wall. See vent graph (Fig. 36) for extended horizontal run if the vertical exceeds 24" (610mm).

1. Establish vent hole through the wall. See page 19
2. Remove soil to a depth of approximately 16" (406mm) below base of snorkel. Install window well (not supplied). Refill hole with 12" (305mm) of coarse gravel leaving a clearance of approximately 4" (100mm) below snorkel. (Fig. 47)
3. Install vent system. See page 19/20, Steps 2 through 5.
4. Ensure a watertight seal is made around the vent pipe coming through the wall.
5. Apply high temperature sealant caulking (supplied) around the 4 and 7 inch 7TDVSKS's snorkel collars.
6. Slide into vent pipe and secure to the wall.
7. Level the soil so as to maintain a 4" (100mm) clearance below snorkel (Fig. 47).

STEP 7

Support the horizontal pipes every 36 inches (914mm) with metal pipe straps. Make sure that the horizontal vent pipe is installed on a level horizontal plane.

STEP 8

Recheck the fireplace to make sure that it is levelled, properly positioned, and nailed or screwed to the floor.

If applied, the fireplaces adjustable frame drywall strips (nailing flanges) should be fastened. See "Framing & Finishing."

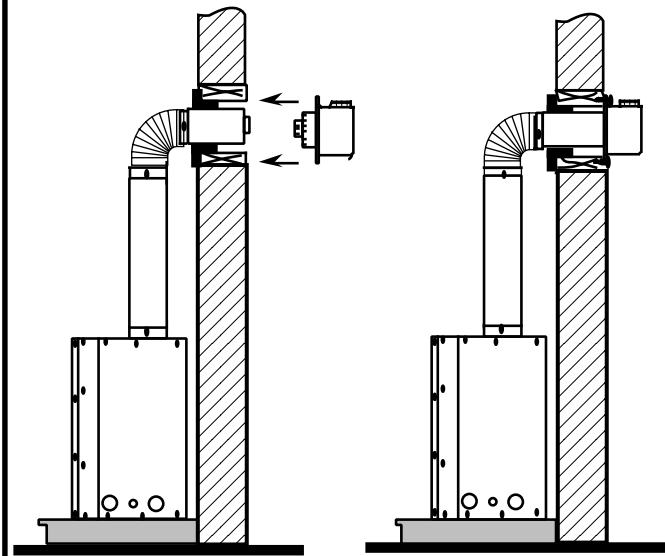

Fig. 46

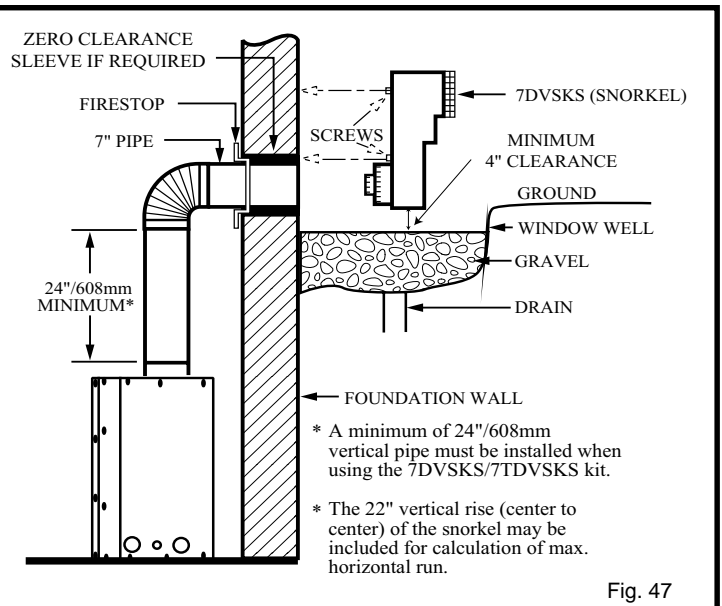
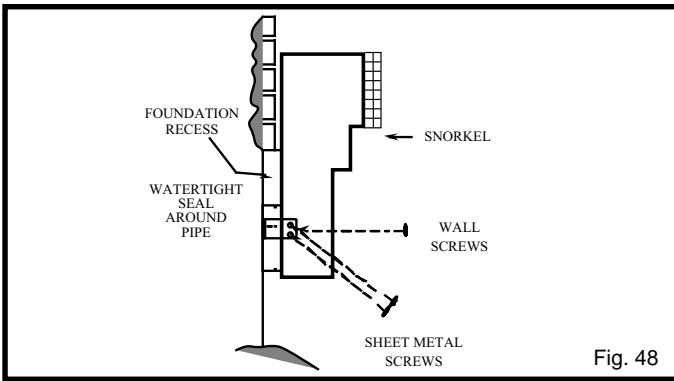

Fig. 47



DO NOT BACK FILL AROUND SNORKEL. SOIL SHOULD NOT BE LESS THAN 4" (100mm) BELOW SNORKEL.



If the foundation is recessed, use recess brackets (not supplied) for securing lower portion of the snorkel. Fasten brackets to wall first and then secure to snorkel with self drilling #8 x 1/2 sheet metal screws. It will be necessary to extend vent pipes out as far protruding wall face (Fig. 48).

VERTICAL THROUGH THE ROOF APPLICATIONS

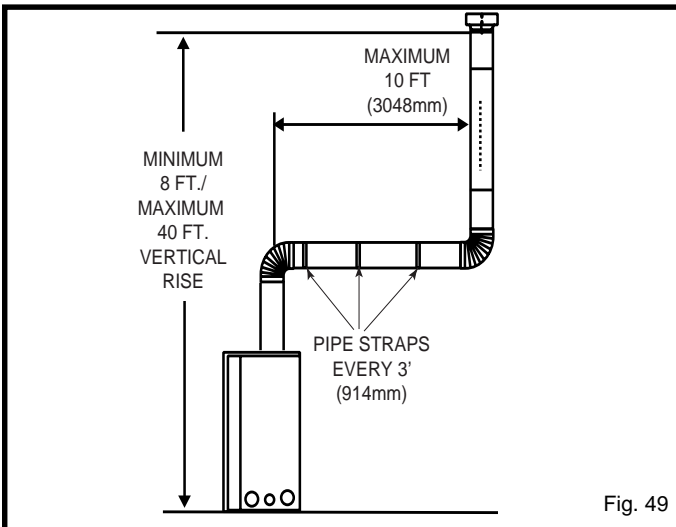

- This Gas Fireplace has been approved for,
- Vertical installations up to 40 feet (12 metres) in height. Up to a 10 ft.(3048mm) horizontal vent run can be installed within the vent system using a maximum of three 90° elbows.
 - Up to two 45° elbows may be used within the horizontal run. For each 45° elbow used on the horizontal level the maximum horizontal length must be reduced by 18 inches (457mm).

Example: Maximum horizontal length

- | | | | |
|---|---|------------|------------------|
| 0 | - | 45° elbows | 10 ft. (3048mm) |
| 1 | - | 45° elbows | 8.5 ft. (2590mm) |
| 2 | - | 45° elbows | 7 ft. (2133mm) |

- A minimum of an 8 ft. vertical rise.
- Two sets of 45 degree elbow offsets within these vertical installations. From 0 to a maximum of 8 ft. (2438mm) a vent pipe can be used between elbows. (Fig. 50)
- 7DVCS must be used to support offsets. (Fig. 51)
This application will require that you first determine the roof pitch and use the appropriate 7TDVSKV (A,B or F). (see Venting Components, page 24)

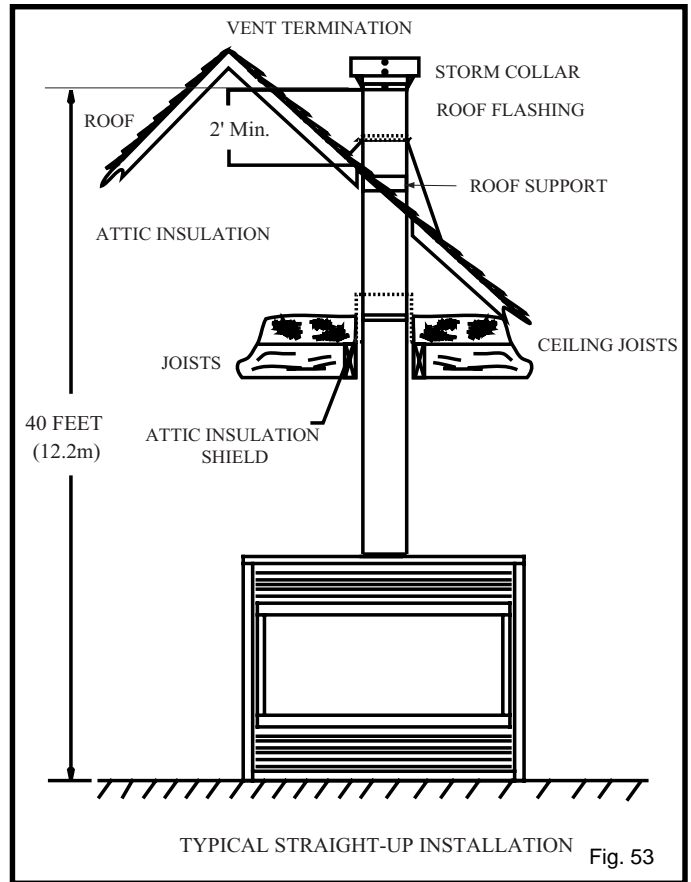
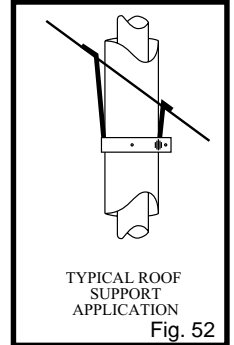
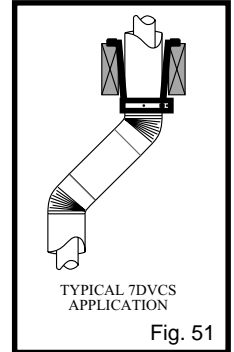
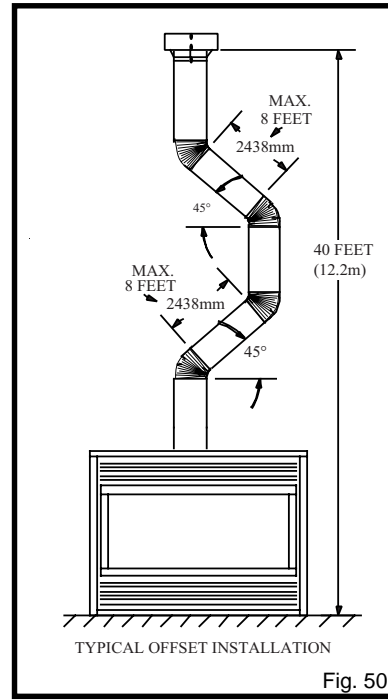

Clearance above a roof shall extend a minimum of 24" (610mm) above the highest point when it passes through the roof surface, and any other obstruction within a horizontal distance of 18" (450mm).



VERTICAL THRU THE ROOF INSTALLATION

1. Locate your fireplace.
2. Plumb to centre of the (4") collar from ceiling above and mark position.
3. Cut opening equal to 9-3/8" x 9-3/8" (240 mm x 240 mm).
4. Proceed to plumb for additional openings through the roof. In all cases, the opening must provide a minimum of 1 inch clearance to the vent pipe, i.e., the hole must be a minimum of 9-3/8" x 9-3/8" (240 mm x 240 mm).
5. Place firestop(s) 7DVFS into position and secure. (Fig. 54)
6. Install roof support (Fig. 52) and roof flashing making sure upper flange of flashing is below the shingles. (Fig. 55)
7. Install appropriate pipe sections until above the flashing. (See Fig. 53 for #'s 7, 8 and 9).
8. Install storm collar and seal around the pipe.
9. Add additional vent lengths for proper height.
10. Apply high temperature sealant to 4" and 7" collars of vent termination and install.

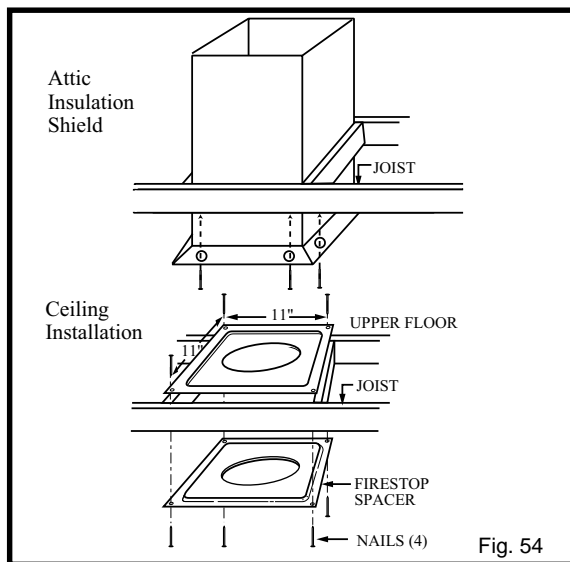

Fig. 54

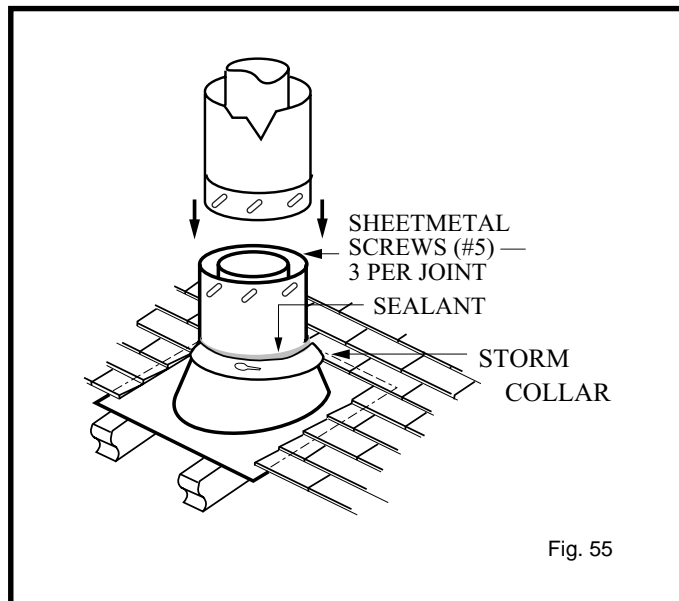

Fig. 55

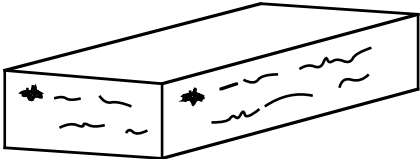
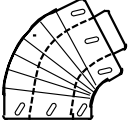
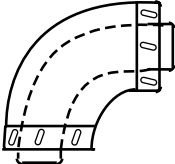
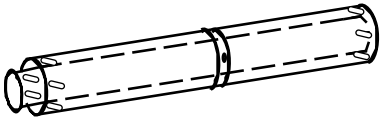
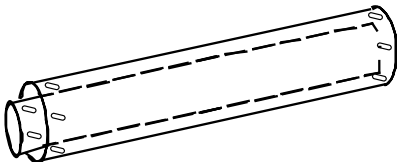
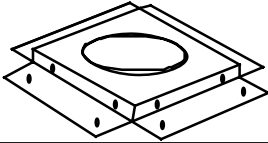
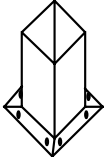
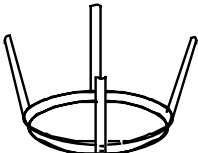
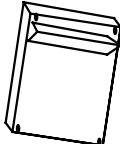

Fig. 54 If there is a room above ceiling level, firestop spacer must be installed on both the bottom and the top side of the ceiling joists. If an attic is above ceiling level a 7DVAIS (Attic Insulation Shield) must be installed.



Fig. 55. The enlarged ends of the vent section always face downward.

TWIST LOCK VENTING COMPONENTS

	<p>Starter Kit - Model 7TDVSK - Sidewall Venting</p> <p>Starter Kit - Model 7TDVSKV - Vertical Venting for 7TDVSKV-A order 1/12 to 6/12 roof pitch for 7TDVSKV-B order 7/12 to 12/12 roof pitch for 7TDVSKV-F order flat roof</p> <p>Starter Kit - Model 7TDVSKS -Snorkel Kit for Below Grade Installation</p>
	<p>45° elbow kit 7DVT45 for Vertical Installation Offsets</p>
	<p>90° transition elbow kit 7TDVRT90 for Vertical Sidewall Applications or thru-the-roof.</p>
	<p>Telescopic vent sections</p> <p>7TDVP1218 - 12" to 18" adjustable length 7TDVP3566 - 35" to 64" adjustable length</p>
	<p>Pipe sections for vertical or horizontal venting</p> <p>Model 7TDVP8" Model 7TDVP12" Model 7TDVP24" Model 7TDVP36" Model 7TDVP48"</p>
	<p>Firestop Spacer Model 7DVFS</p>
	<p>Attic Insulation Shield Model 7DVAIS</p>
	<p>Vertical/Horizontal Combination Offset Support Model 7DVCS</p>
	<p>7DVSS Siding Shield (to protect siding)</p>

OPERATING INSTRUCTIONS

GENERAL GLASS INFORMATION



Only glass approved for use in Majestic products may be used for replacement.

1. The use of substitute glass will void all product warranties.
2. Care must be taken to avoid breakage of the glass.
3. Under no circumstances should this appliance be operated without the front glass or with a broken glass. Replacement of the glass (with gasket) as supplied by the manufacturer should be done by a licenced qualified service person.

LOUVRE REMOVAL

(Fig. 56) To remove top louvre pull louvre up and then lift out.

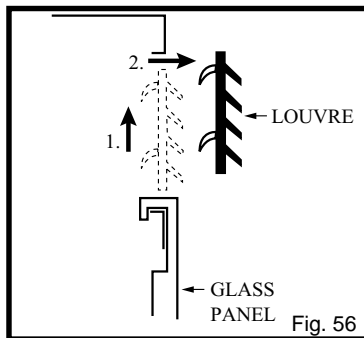

GLASS FRAME REMOVAL

1. Shut off gas.
2. Let the fireplace cool if it has been operating.
3. Remove top louvre. (See Louvre Removal)
4. Open the lower louvre assembly.
5. Release the two clamps at the bottom of the window frame by pulling down on the clamp handles.
6. Lift off the glass frame as shown.
7. To reinstall glass follow the above procedure in reverse. (Fig. 57)

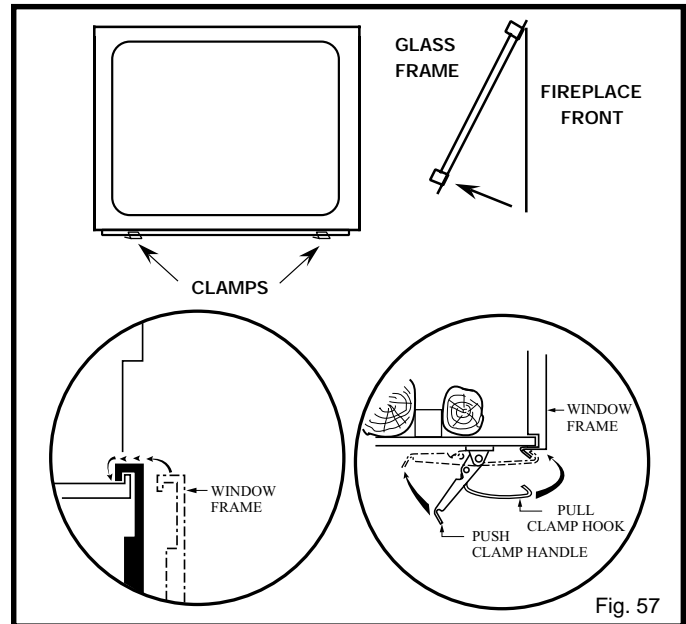

GLASS CLEANING

It will be necessary to clean the glass periodically. During start-up condensation, which is normal, forms on the inside of the glass and causes lint, dust and other airborne particles to cling to the glass surface. Also initial paint curing may deposit a slight film on the glass. It is therefore recommended that the glass be cleaned two or three times with a non-ammonia household cleaner and warm water (we recommend gas fireplace glass cleaner). After that the glass should be cleaned two or three times during each heating season depending on the circumstances present.



- Clean glass after first two weeks of operation.
- Do not clean glass when hot.
- Do not use abrasive cleaners.
- Do not strike or slam the glass.

INSTALLATION OF LOGS

1. Remove front glass. (See "Glass Removal" Section)
2. Remove logs from the packaging.



As with all plastics — these are not toys and should be kept away from children and infants.

3. Place rear log (BH2) on rear bracket (ensure log is seated properly, leveled and centered to the unit), so it will not move from side to side and it is firmly positioned on the bracket.
4. Place front log (BH1) on front log support. Use log's bottom holes to locate it.
5. Place top left log (BH3) onto locator notches. Ensure log is secure.
6. Place top right log (BH4) onto locator notches. Ensure log is secure.

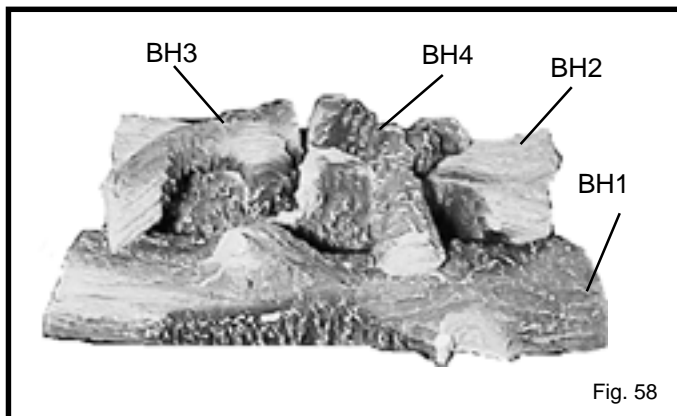

Fig. 58

LAVA ROCK

The lava rock provided with this fireplace must be placed on the firebox base on either side of the burner assembly.



Under no circumstances should this lava rock be placed on any part of the burner assembly.

FLAME ADJUSTMENT

For fireplaces equipped with Hi/Lo valves, flame adjustment is accomplished by rotating the Hi/Lo adjustment knob located near the centre of the gas control. Fig. 59/60.

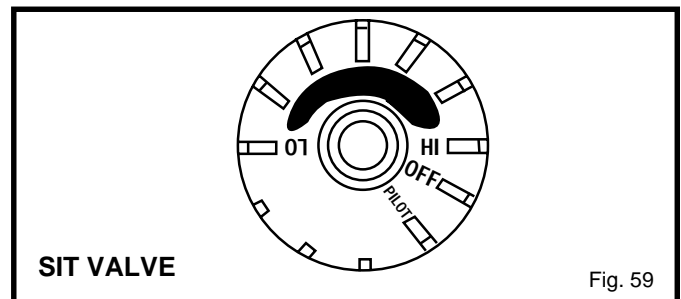

Fig. 59

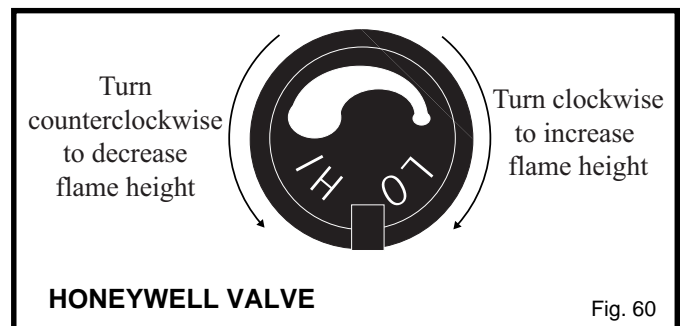
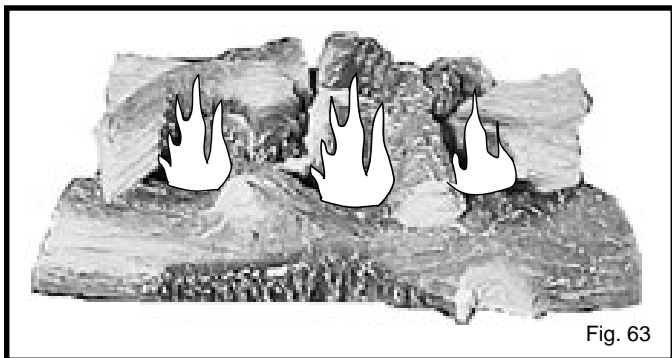
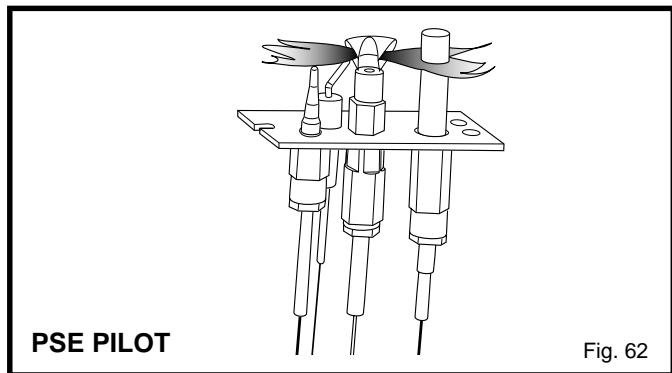
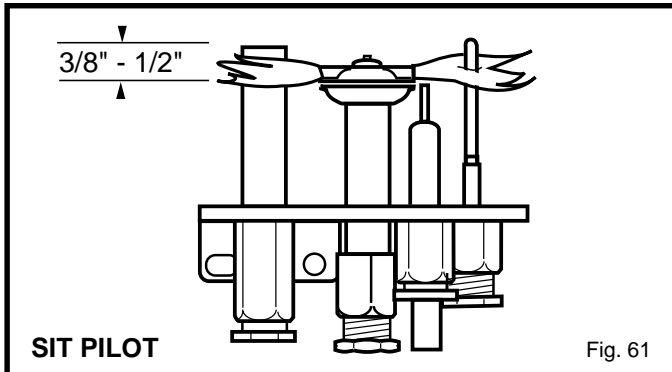

Fig. 60

FLAME CHARACTERISTICS



It is important to periodically perform a visual check of the pilot and the burner flames. Compare them to the pictorials illustrated below (Fig. 61, 62 and 63). If any of the flames appear abnormal call a service person.



INSPECTING THE VENTING SYSTEM

This appliance venting system was designed and constructed to develop a positive flow adequate to remove flue gases to the outside atmosphere.

Any foreign objects in the venting system, except those designed specifically for the venting system, may cause spillage of flue gases.

To inspect the venting system, make sure the main gas valve is off. Remove glass door (See Glass Door Removal). Using a flashlight, check the area above the baffle in the combustion dome. Clean if necessary.

MAINTENANCE

1. It is important to keep the burner and the burner compartment clean. This must be done periodically, at least once per season.
2. Clean the brass trim using a soft clean cloth, slightly dampened with lemon oil and buff with a soft clean cloth. Do NOT use brass polish or household cleaners as these products will damage the brass trim. Lemon oil can be obtained at supermarkets or hardware stores.
3. The optional FK24 fan does require periodic cleaning. Check the area under the control door and in front of the fan and wipe or vacuum at least once a month during the operating season.
4. Contact your local representative to arrange an annual service program.

CLEANING THE STANDING PILOT CONTROL SYSTEM

The burner and control system consists of:

- burner tube
- gas orifices
- pilot assembly
- thermopile
- millivolt gas valve

Most of these components may require only an occasional checkup and cleaning and some may require adjustment. If repair is necessary, it should be performed by a qualified technician.

1. Turn off pilot light at gas valve side
2. Let fireplace cool if it has been running.
3. Remove glass. (see Glass Removal)
4. Remove logs,



LOGS MAY BE HOT

5. Vacuum burner compartment especially around orifice primary air openings.
6. Visually inspect pilot. Brush or blow away any dust or lint accumulation.
7. Reinstall logs.
8. Ignite pilot - see Operating Section of Manual.
8. Reinstall glass.

To obtain proper operation, it is imperative that the pilot and burner's flame characteristics are steady, not lifting or floating.

Typically, the top 3/8" or 1/2" of the thermopile should be engulfed in the pilot flame. See Fig. 61 or 62.

To adjust pilot burner (by a Qualified Service Representative)

1. Remove pilot adjustment cap.
2. Adjust pilot screw to provide properly sized flame.
3. Replace pilot adjustment cap.

The primary air shutter is set at factory and should only be adjusted (if necessary) by a qualified service person.

LIGHTING AND OPERATING INSTRUCTIONS

FOR YOUR SAFETY READ BEFORE LIGHTING

WARNING: If you do not follow these instructions exactly, a fire or explosion may result causing property damage, personal injury or loss of life.

- A. This fireplace has a pilot which must be lit manually. When lighting the pilot follow these instructions exactly.
- B. BEFORE LIGHTING smell all around the fireplace area for gas. Be sure to smell next to the floor because some gas is heavier than air and will settle on the floor.
- WHAT TO DO IF YOU SMELL GAS**
- Do not try to light any fireplace.
 - Do not touch any electric switch
 - Do not use any phone in your building
 - Immediately call your gas supplier from a neighbor's phone. Follow the gas supplier's instructions.
 - If you cannot reach your gas supplier, call the Fire Department
- C. Use only your hand to push in or turn the gas control knob. Never use tools. If the knob will not push in or turn by hand, do not try to repair it, call a qualified service technician. Applying force or any attempted repair may result in a fire or explosion.
- D. Do not use this fireplace if any part has been under water. Immediately call a qualified service technician to inspect the fireplace and to replace any part of the control system and any gas control which has been under water.

LIGHTING INSTRUCTIONS

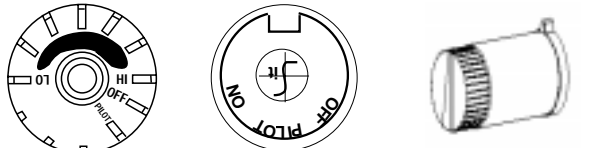
1. STOP! Read the safety information above on this label
 2. Turn off all electrical power to the fireplace.
 3. For MN/MP/TN/TP appliances ONLY, go on to Step 4. For RN/RP appliances turn the On/Off switch to off position or set thermostat to lowest level.
 4. Open control access panel.
 5. Push in gas control knob slightly and turn clockwise to "OFF". Do not force.
- 

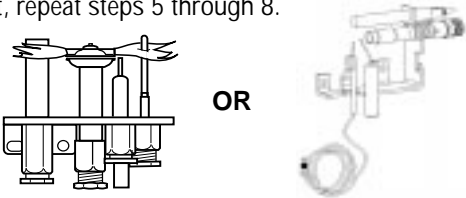
EURO SIT **SIT NOVA** **HONEYWELL**
6. Wait five (5) minutes to clear out any gas. Then smell for gas, including near the floor. If you smell gas, **STOP!** Follow "B" in the safety information above on this label. If you don't smell gas, go to the next step.
 7. Remove glass door before lighting pilot. (See Glass Frame Removal in manual).
 8. Visibly locate pilot by the main burner.
 9. Turn knob on gas control counterclockwise to "PILOT".
 10. Push the control knob all the way in and hold. Immediately light the pilot by repeatedly depressing the piezo spark ignitor until a flame appears. Continue to hold the control knob in for about one (1) minute after the pilot is lit. Release knob and it will pop back up. Pilot should remain lit. If it goes out, repeat steps 5 through 8.
- 

OR
- If knob does not pop up when released, stop and immediately call your service technician or gas supplier.
 - If after several tries, the pilot will not stay lit, turn the gas control knob to "OFF" and call your service technician or gas supplier.
11. Replace glass door.
 12. Turn gas control knob to "On" position.
 13. For Rn/RP appliances turn the On/Off switch to "On" position or set thermostat to desired setting.
 14. Turn on all electrical power to the fireplace.

TO TURN OFF GAS TO FIREPLACE

1. Turn the On/Off switch to Off position or set the thermostat to lowest setting.
2. Turn off all electric power to the fireplace if service is to be performed.
3. Open control access panel.
4. Push in gas control knob slightly and turn clockwise to "OFF". Do not force.
5. Close control access panel.

TROUBLE SHOOTING THE GAS CONTROL SYSTEM

HONEYWELL MILLIVOLT VALVE

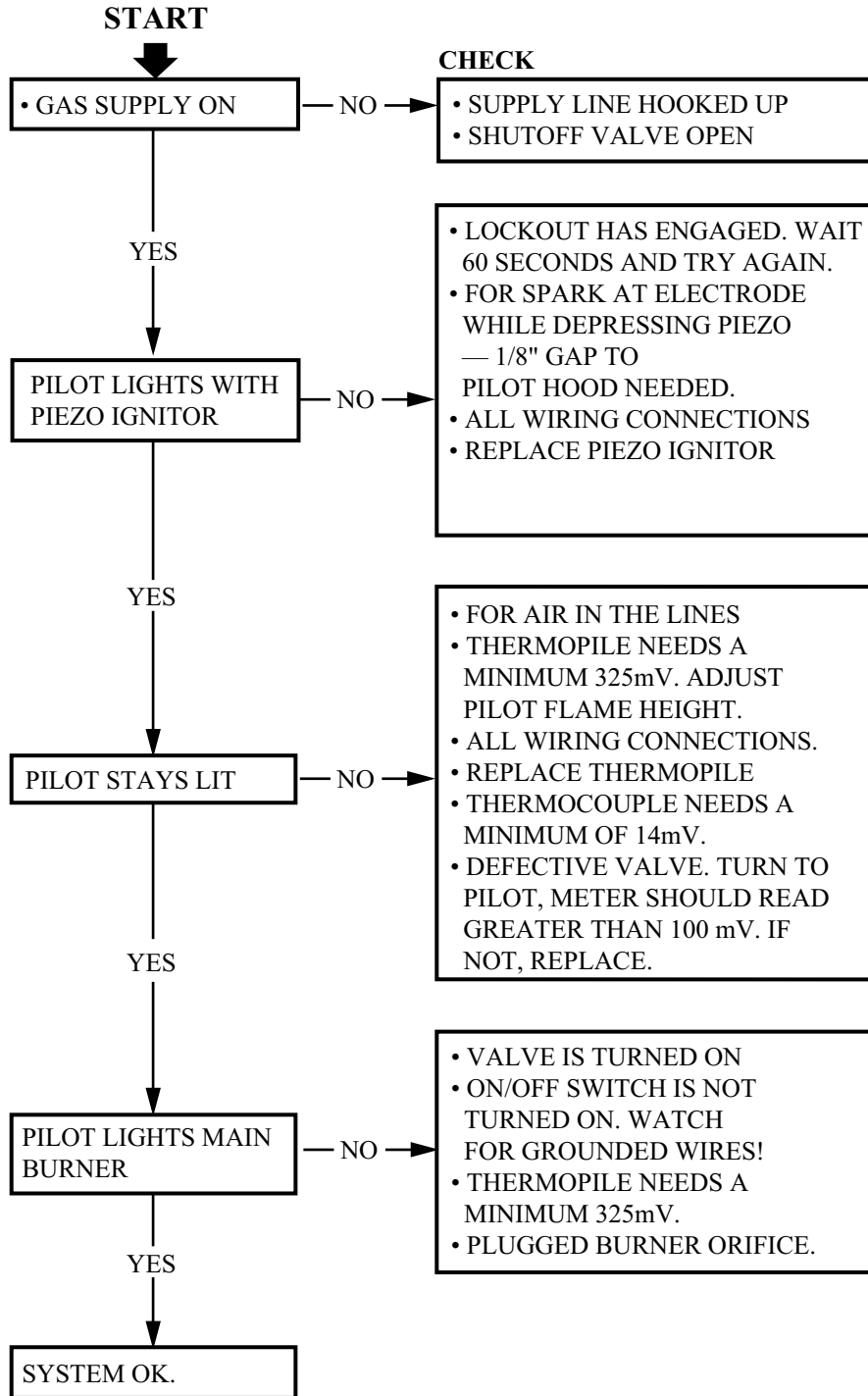

REPLACEMENT PARTS LIST

	DESCRIPTION	BHDR36
1.	Log Set Complete	10001818
1a.	Log Front	BH1
1b.	Log Rear	BH2
1c.	Log Top Left	BH3
1d.	Log Top Right	BH4
2.	Lava Rock (Package)	10001454
3.	Burner Tube Assembly	10001811
4a.	Orifice Burner (Nat)	SEE RATING PLATE FOR ORIFICE SIZE
4b.	Orifice Burner (Prop)	SEE RATING PLATE FOR ORIFICE SIZE
5a.	Orifice Pilot SIT (Nat)	54273
5b.	Orifice Pilot SIT (Prop)	54272
6a.	Orifice Pilot PSE (Nat.)	10001822
6b.	Orifice Pilot PSE (Prop.)	10001823
7a.	Pilot Assembly SIT (Nat)	10000672
7b.	Pilot Assembly SIT (Prop)	10000673
8a.	Pilot Assembly PSE (Nat.)	10001741
8b.	Pilot Assembly PSE (Prop.)	10001742
9.	Pilot SIT	10001295
10.	Pilot w/ignitor and cable PSE	10001824
11.	Pilot Tubing w/fittings	10001296
12.	Manifold Tubing w/fittings	57318
13.	Thermocouple SIT	53373
14.	Thermocouple PSE	10001825
15.	Thermopile	51827
16.	Electrode Ignitor w/cable SIT	10001297
17.	Ignitor Piezo SIT	52464
18.	Ignitor Piezo Honeywell	20000062
19a.	Valve SIT 820 (RN)	52677
19b.	Valve SIT 820 (RP)	52678
20a.	Valve Honeywell (RN)	10001782
20b.	Valve Honeywell (RP)	10001759
21.	Fan with bracket	54103
22.	Electrical Cord (6ft)	51865
23.	Fan Temperature Sensor	51704
24.	Speed Control	51738
25.	Speed Control Knob	51882
26.	Glass with Gasket	10001781
27.	Gasket Glass	57317
28.	Frame Window	10001425
29.	Clamp Frame Window	54174
30.	Trim Frame Window (PB) (w/2 magnets)	57480
31.	Top Louvre Assembly	10000037
32.	Bottom Louvre Assembly	10000038
33.	Access Door Hinge	52356
34.	Remote Switch	51842
35.	Ceramic Refractory Lining Kit (Optional)	36BDVCR
36.	Screen Kit (Optional)	36BDVTKS
37.	Remote Switch Kit (Not Shown)	53875

OPTIONAL FAN KIT - FK24

Fan Specifications: 120 Volt 60 HZ .75 Amp.

This fan does not need regular maintenance, however periodic cleaning is required. Check the area under the control door and in front of the fan and wipe or vacuum at least once a month during the operating season.



Should this fan require servicing, the power supply must be disconnected.

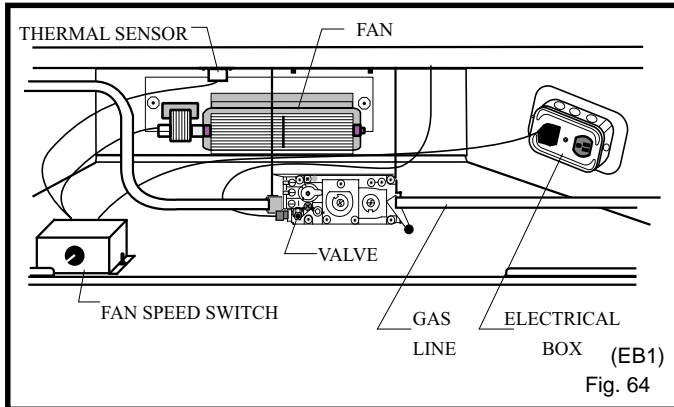

Fig. 64



The FK-24 comes with the electrical cord attached.

- Slide fan assembly from the left side into fireplace opening, line up mounting holes with screw studs on back of fireplace and fasten with #10-24 hex nuts.
- Install thermal sensor on bottom of firebox using #10-24 hex nuts.
- (Option A)** - Place electronic fan speed control box on bottom of fireplace base, lining up mounting holes with screw studs. Fasten fan speed control box with #10-24 hex nuts.
(Option B) - The speed control can be installed in an electrical box at normal wall switch height for convenient access.
- Remove electrical knockout on the side of the fireplace. (See hard wire or receptacle hook up instructions).
- Whether wiring directly to the fan junction box (Option A) or into the EB1 (electrical receptacle box, P/N ZA1200, Option B) first ensure cable is secured using box connector.

THE FIREPLACE, WHEN INSTALLED MUST BE ELECTRICALLY CONNECTED AND GROUNDED IN ACCORDANCE WITH LOCAL CODES OR, IN THE ABSENCE OF LOCAL CODES, WITH THE CURRENT CSA C22.1 CANADIAN ELECTRICAL CODE or for U.S.A. INSTALLATIONS, FOLLOW LOCAL CODES AND THE NATIONAL ELECTRICAL CODE, ANSI/NFPA NO. 70.



Any electrical re-wiring of this fan must be done by a qualified electrician.



Turn off all power before hook-up.

WIRING INSTRUCTIONS

Hard (Direct) Wire Hook-Up

First connect ground wire to ground stud located on the base of either box. Black wire from supply should connect to the variable speed switch. Alternate speed switch wire connects to temperature sensor. Alternate lead from sensor connects to fan. Alternate fan lead connects back to the white supply wire. (Fig. 65).

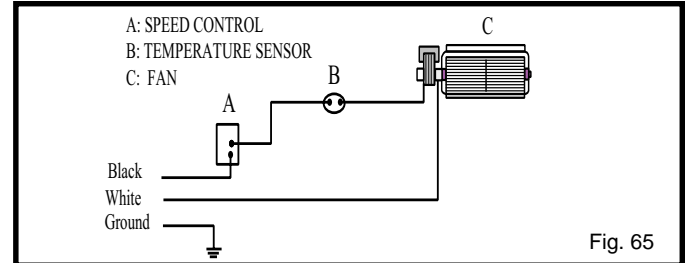

Fig. 65

OPTIONAL EB1 (Receptacle) Hook-Up

- Remove 2" knock out. Slide the electrical box back plate into the back and bottom lances (clips) while fitting the box connector into the knock out. Fasten into place with fastening screws provided. Fig. 66.
- Connect the black positive wire to brass screw (polarized side) of the receptacle. The white wire is connected to the chrome screw. The ground wire is connected to the green ground screw of the receptacle. Fit the receptacle into the electrical box.
- Screw the cover plate provided to the electrical box.
- Plug in the FK24 Fan Kit.

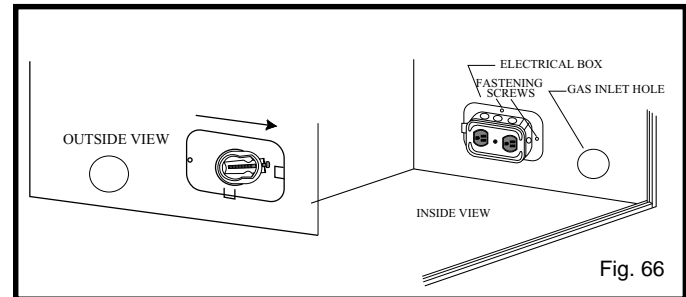

Fig. 66

OPTIONAL BAY WINDOW INSTALLATION

- Remove existing bottom louvre and hinges from fireplace. (Set aside the two (2) self tapping screws).
- Remove existing top louvre from fireplace.
- Remove two (2) pieces of ceramic refractory from Bay Window Frame; considering that these are very fragile pieces handle them with special care!
- Assembly Bay Window Frame to Bottom Bay Louvre by using four (4) machine screws (from top to bottom), four (4) nuts (in the bottom) and four (4) spacers (all supplied with the kit) through the existing four (4) holes in the bottom of the Bay Window Frame and in the top of the Bottom Bay Louvre. Spacers to be placed between the Bay Window Frame and the Bottom Bay Louvre.
- Insert two (2) pieces of ceramic refractory into the Bay Window Frame as per drawing below.

6. Hang Bay Window Frame assembly over existing glass frame.



Do not remove existing glass frame

7. Re-install top louvre assembly.



Remove all plastic from brass trims

8. Open the Bottom Bay Louvre door and screw two (2) self tapping screws (as per step 1 above) to the bottom of the unit where the hinges were

9. Bottom brass trim is removable when unit is installed with marble or tile surround which cover the fireplace bottom.

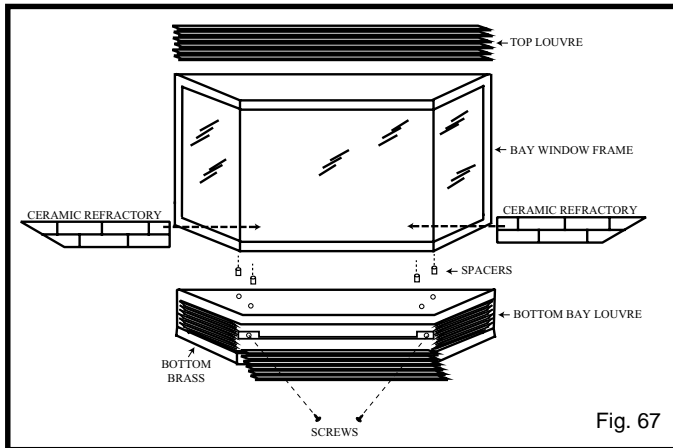

Fig. 67

OPTIONAL SCREEN KIT INSTALLATION



WARNING: DO NOT install the frame window screen with the fireplace ON

To install the Frame Window Screen:

- 1- Slide the top edge of the frame window screen through the slots beneath the main frame window top trim support.
- 2- Make the frame window screen parallel to the main frame window.
- 3- Slide the bottom edge of the frame window screen into the space that exist between the glass and the main frame window bottom trim support.

To remove the Frame Window Screen:



WARNING: If the fireplace is ON, turn it OFF and wait until the temperature of the window screen is cool enough to handle.

- 1- Lift the frame window screen moving it parallel to the glass.
- 2- Move the bottom side of the frame window screen away from the glass.
- 3- Slide the frame window screen down from the top trim support.

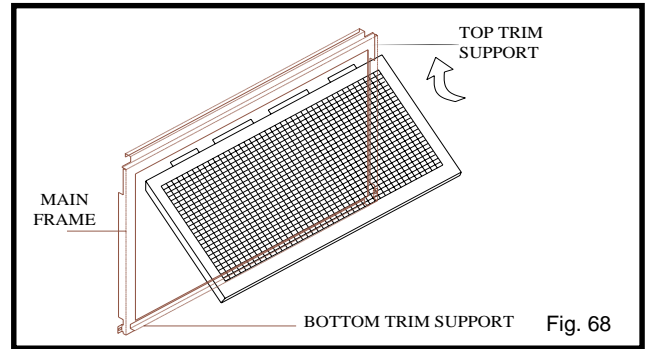

Fig. 68

OPTIONAL CERAMIC REFRACTORY INSTALLATION

1. Remove glass and logs.
2. Place refractory side supports so that the hole fits over the screw head on the firebox floor.
3. Place refractory base sides on the floor of the firebox.
4. Place back refractory - small brick edge down into support (See Fig. 70).
5. Attach adjustable tabs, packed with refractory, onto the studs found on the top of the firebox using the 2-10/24 nuts provided.
6. Slide side panels into side supports and behind side tab and adjust, fitting the ceramic tight to the side of the firebox. Tighten nuts. Fig. 69.



Mortar lines must be lined up.

7. Place refractory bottom centre in front of the burner.

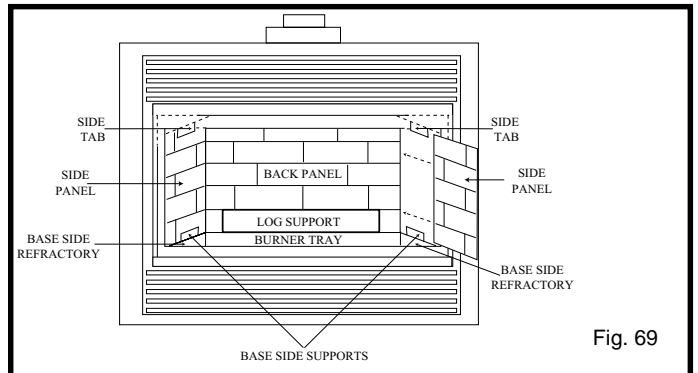

Fig. 69

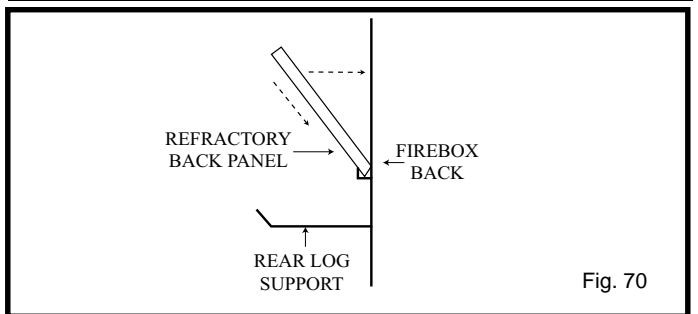

Fig. 70

OPTIONAL REMOTE CONTROL

- MRC1 - On/Off Button Remote Control
- MRC2 - Temperature Control Remote
- MRC3 - Temperature Control w/digital display & 24 hour programmable clock
- IMT - Wall Mounted Thermostat Control